

***Workshop Manual - Rebuild air spring cartridge***

# SAFETY PRECAUTIONS

## General Warnings

### **Note!**

*When working with the Öhlins product, always read the Vehicle Service Manual.*

### **Note!**

*The shock absorber/front fork/steering damper is an important part of the vehicle and will affect the stability.*

### **Note!**

*Read and ensure you understand the information in this manual and other technical documents provided by Öhlins, before using the product.*

### **Note!**

*Öhlins Racing AB can not be held responsible for any damage to the shock absorber/front fork/steering damper, vehicle, other property or injury to persons, if the instructions for mounting, usage and maintenance are not followed exactly.*

### **Warning!**

*After installing the Öhlins product, take a test ride at low speed to ensure your vehicle has maintained stability.*

### **Warning!**

*If the suspension makes an abnormal noise, or the function is irregular, or if you notice any leakage from the product, stop the vehicle immediately and return the product to an Öhlins Service Centre.*

### **Warning!**

*The product warranty shall only apply if the product has been operated and maintained in accordance with recommendations in this manual. If you have any questions regarding usage, service, inspection and/or maintenance please contact Öhlins.*

### **Note!**

*Before working on the product make sure that the vehicle is washed and cleaned properly. Do not use alcobased products on the outside or inside of the product.*

## Product Specific Warnings

### **Warning!**

*This product was developed and designed exclusively for a specific vehicle model and shall only be installed on the intended vehicle model in its original condition as delivered from the vehicle manufacturer.*

### **Warning!**

*This product is pressurized. Do not open, service or modify this product without proper education (authorized Öhlins dealer/distributor) and proper tools.*

### **Caution!**

*Do not use a pressure washer or a power washer when cleaning the fork.*

## SAFETY SYMBOLS

*In this manual, mounting instructions and other technical documents, important information concerning safety is distinguished by the following symbols:*



*The Safety Alert Symbol means: Warning! Your safety is involved.*

### **Warning!**

*The Warning Symbol means: Failure to follow warning instructions can result in severe or fatal injury to anyone working with, inspecting or using the shock absorber/front fork, or to bystanders.*

### **Caution!**

*The Caution Symbol means: Special precautions must be taken to avoid damage to the shock absorber.*

### **Note!**

*The Note Symbol indicates information that is important regarding procedures.*

© Öhlins Racing AB. All rights reserved.

Any reprinting or unauthorized use without the written permission of Öhlins Racing AB is prohibited.

## TABLE OF CONTENTS

Tools .....	3
Overview - General layout .....	3
Kit contents .....	4
Remove air spring from lower legs (RXF34/RXF36/RXF36 m.2) .....	5
Remove air spring from lower legs (DH38) .....	7
Rebuild of air spring cartridge .....	9
Reinstall air spring cartridge (RXF34/RXF36/RXF36 m.2) .....	22
Reinstall Air spring cartridge (DH38) .....	23
Appendix A .....	24

# REBUILD AIR SPRING CARTRIDGE

## Tools

1	18860-01	Hex socket 28 mm
2	18860-03	Seal head tool 14
3	19245-01	Multi clamp TTX18
4	-	Cassette locking tool

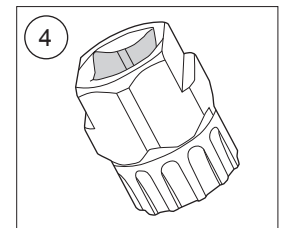
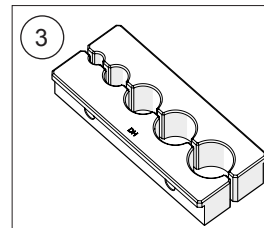
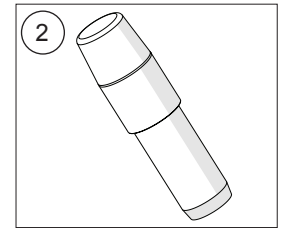
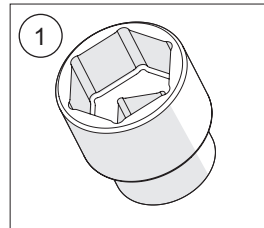

## Oil, grease, thread locker and sealant

Fork lubrication fluid	01336-01 - Renep CGLP 68 Fork lube 1L
Air spring lubrication fluid	01337-06 - Renep CGLP 220 Air spring lube 0.6L
Function grease	01338-22 - Renolit SI 410 M Silicone grease 225g
Assembly grease	Slickoleum / Buzzy's Slick Honey
Loctite 243	01791-03
Loctite 577	01791-07

## Overview - General layout

1 Chassis

2 Air Spring Cartridge

3 Damper Cartridge

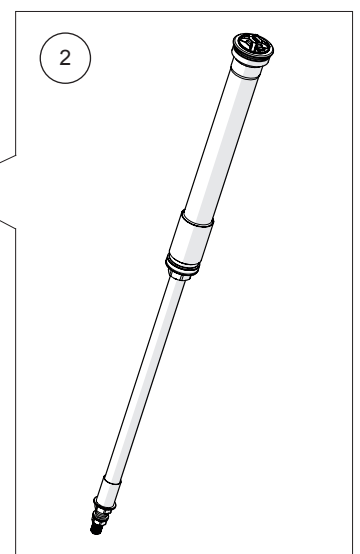
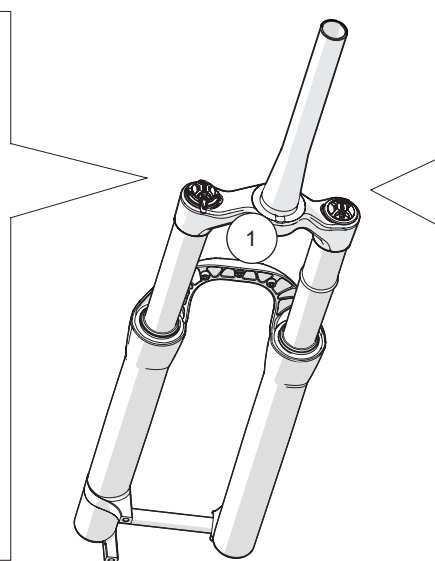
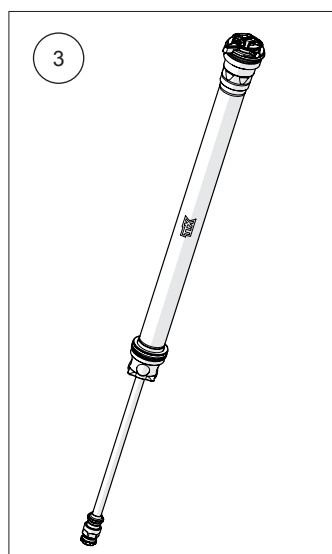

















# REBUILD AIR SPRING CARTRIDGE

## Kit contents

1	18850-13	Rebuild kit air spring
---	----------	------------------------

The following service kits (expiring) can also be used:  
DH38: 19242-02

1

 00576-23 O-ring	 x2 00338-39 O-ring	 00576-06 O-ring	 03070-01 Scraper	 18649-01 Bump rubber	 18641-01 Back-up ring	 18639-01 X-ring
 18637-01 O-ring	 18629-02 X-ring	 x2 18628-01 O-ring	 x2 18607-01 Air valve schrader	 x2 18556-03 Back-up ring	 x2 00638-86 O-ring	 00438-57 O-ring
 00338-68 O-ring	 00338-57 O-ring	 18612-04 O-ring				

# REBUILD AIR SPRING CARTRIDGE

## Remove air spring from lower legs (RXF34/RXF36/RXF38)

### 👁 Note!

Record the rebound adjuster setting and the pressure in the positive air chamber and ramp up chamber before service. We recommend using a bike stand to clamp the steering tube when working on the fork.

1. Thoroughly clean the outside of the fork from dirt or grit. Place the fork in a bike stand according to picture with air spring side pointing upwards and the fork on the right hand side of the clamp jaws.

2. Release the air from the positive air chamber at the top and the ramp up chamber at the bottom.

3. Use a socket wrench with a 12/14 mm deep hex socket to remove the nut and the washer (for 12 mm) on the lower air valve.

4. Use a socket wrench with a hex socket 28 mm (18860-01) or a cassette locking tool to loosen the air spring.

### 👉 Caution!

Do not use an adapter between wrench and socket, as this will increase the risk of damaging the anodized finish of the top cap.

### 👁 Note!

When removing the Air Spring cartridge, it is easy to damage the Top Cap. Put pressure on the wrench while unthreading the Top Cap.

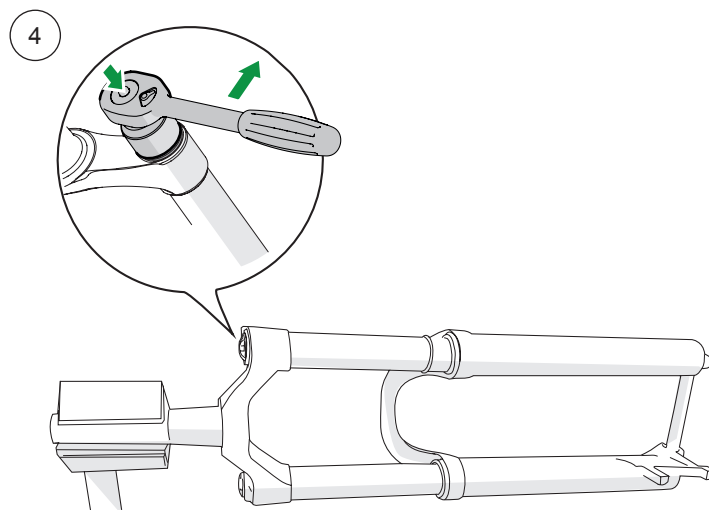
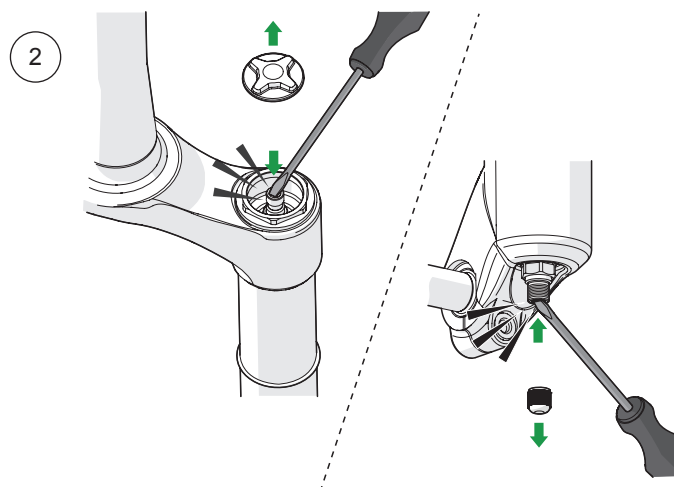
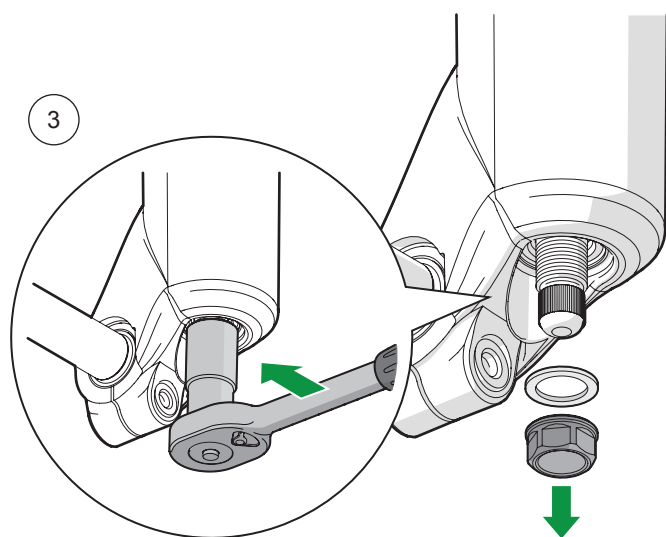
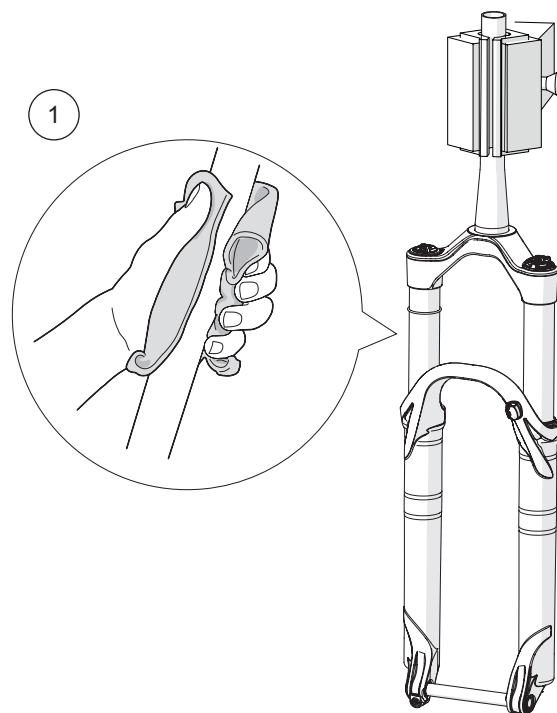

# REBUILD AIR SPRING CARTRIDGE

5. Slide the air spring off the stanchion tube.

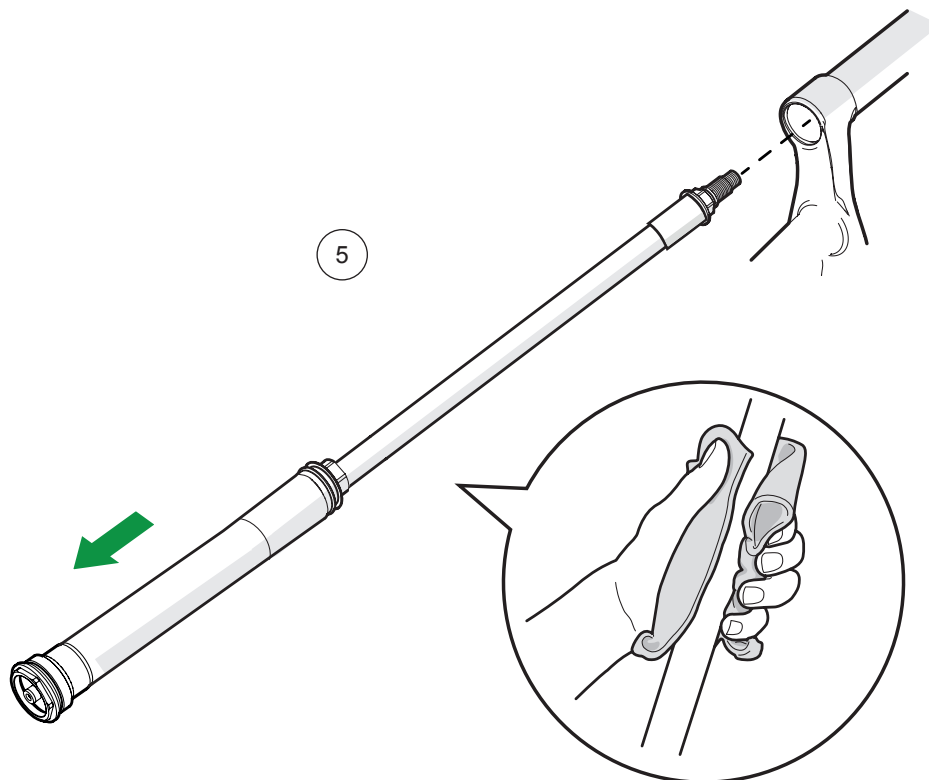

# REBUILD AIR SPRING CARTRIDGE

## Remove air spring from lower legs (DH38)

### 👁 Note!

Record the rebound adjuster setting and the pressure in the positive air chamber and ramp up chamber before service. We recommend using a bike stand to clamp the steering tube when working on the fork.

1. Thoroughly clean the outside of the fork from dirt or grit.
2. Release the air from the positive air chamber at the top and the ramp up chamber at the bottom.
3. Remove the golden bash cap for the air spring side by unscrewing it by hand.
4. Remove the nut on the air spring side by using a socket wrench with a 14 mm deep hex socket.
5. Use a socket wrench with a hex socket 28 mm (18860-01) or a cassette locking tool to loosen the air spring to loosen the air spring.

### 👁 Note!

When removing the air spring cartridge, it is easy to damage the top cap. Put pressure on the wrench while unthreading the top cap. If needed use tripple clamp to hold stanchion tube.

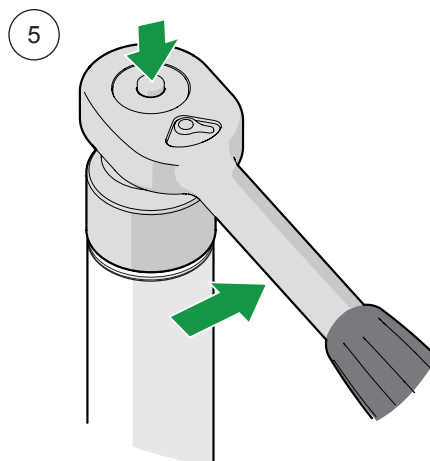
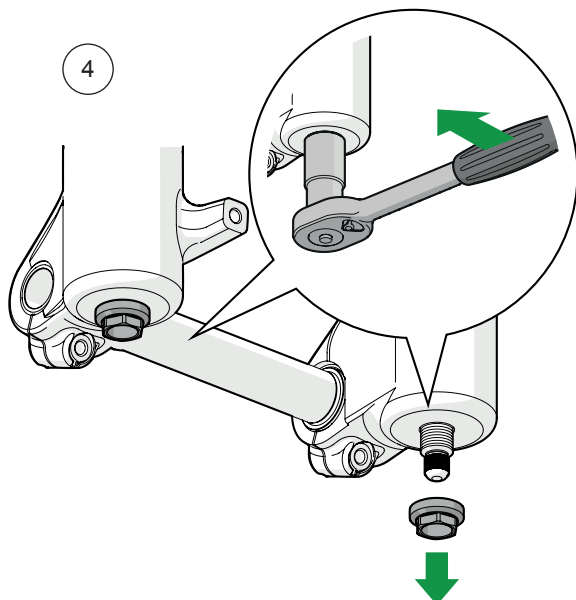
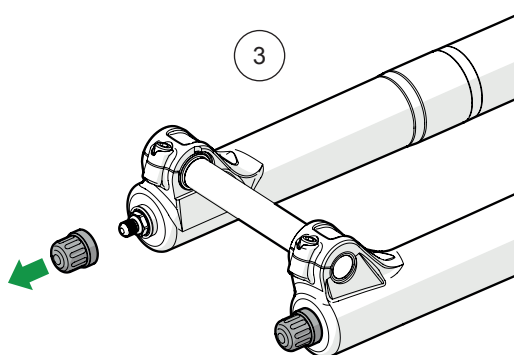
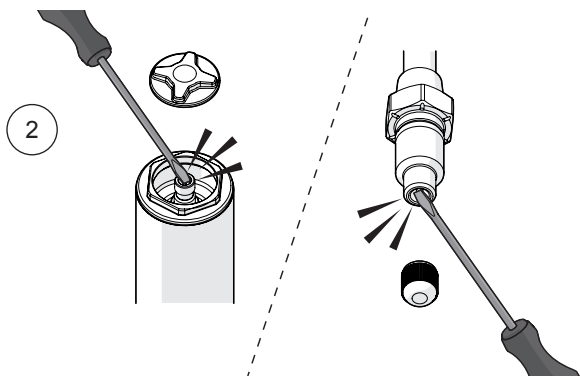
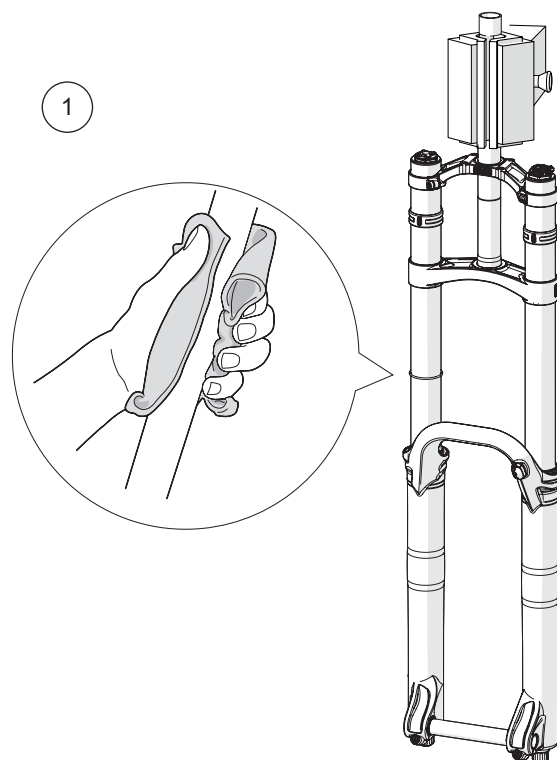

# REBUILD AIR SPRING CARTRIDGE

6. Slide the air spring off the stanchion tube.

**⚠ Warning!**

*Make sure the pressure inside the air spring is removed.*

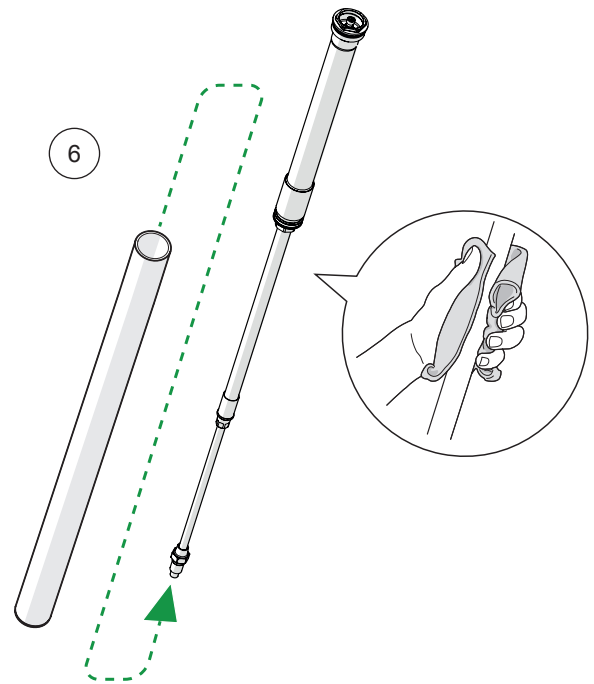



# REBUILD AIR SPRING CARTRIDGE

## Rebuild of air spring cartridge

### 👁 Note!

Clean all parts using disc brake cleaner and a rag to remove dirt, old grease and thread sealant before reassembling. Lubricate new o-rings/x-rings etc. with fresh Assembly grease.

### 👁 Note!

Use a vise and the appropriate shaft clamps when servicing the front fork.

1. If you used a cassette tool to undo the top cap leave the pre-applied thread locker(reusable) and continue. If you used a 28 mm socket clean top cap threads (male and female) using a rag covered by degreaser or brake cleaner. Use a nylon bristled brush to remove any remaining residue from threads.

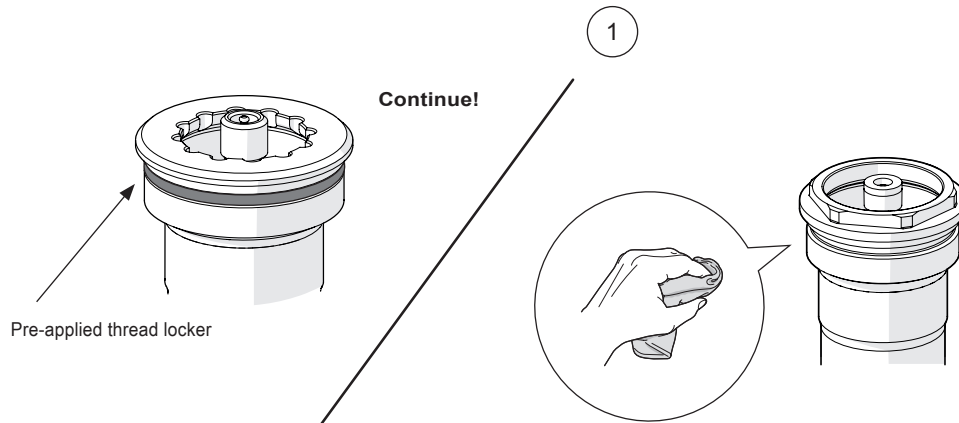

# REBUILD AIR SPRING CARTRIDGE

2. Remove the old o-ring (00576-06/00576-23) from the top cap.
3. Install a new o-ring (00576-06/00576-23) on the top cap.
4. Remove the old air valve schrader (18607-01) from the top cap.
5. Install a new air valve schrader (18607-01) into the top cap.
6. Remove the old o-ring (00438-57) from the seal head.
7. Install a new o-ring (00438-57) on the seal head.
8. Remove the old o-ring (18612-04/00338-57) from the base cap.
9. Install a new o-ring on the base cap. For end shaft nut M10 use 18612-04 and for M12 use 00338-57.

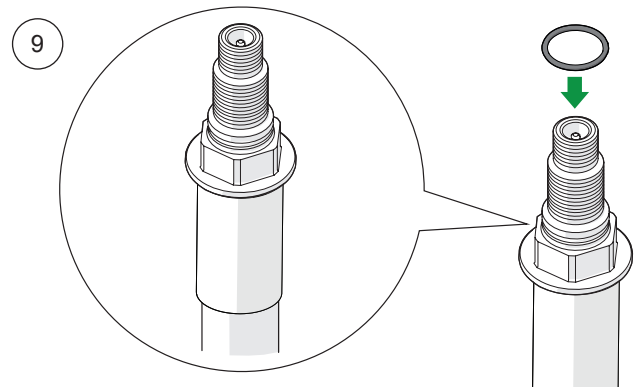
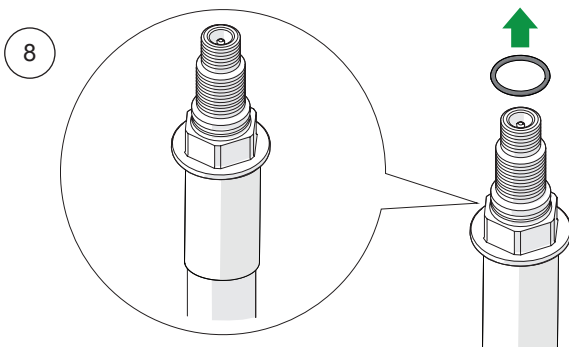
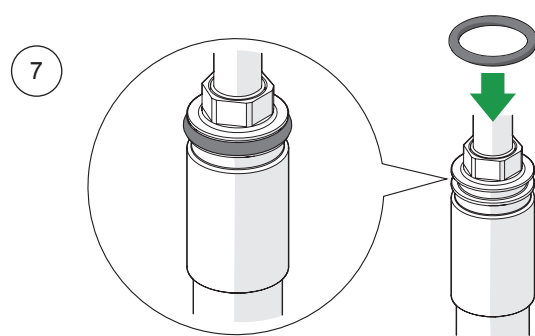
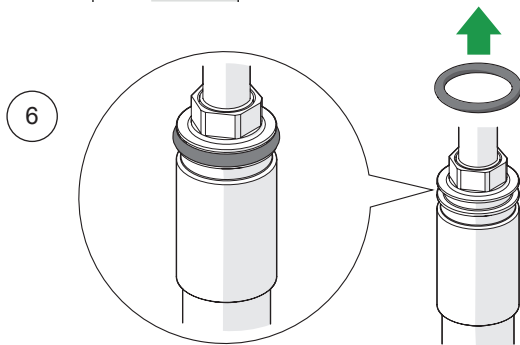
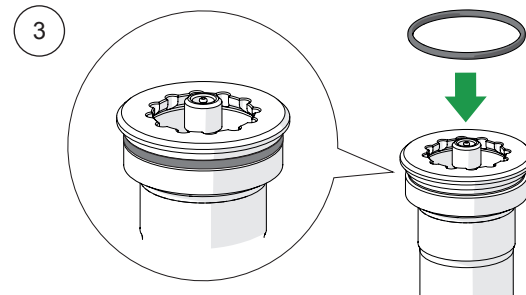
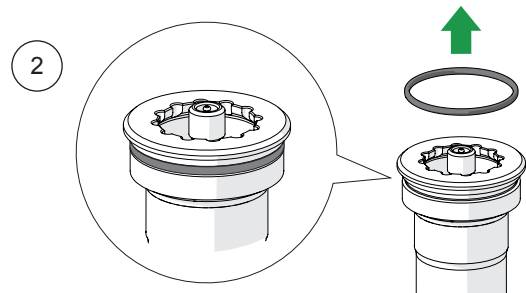
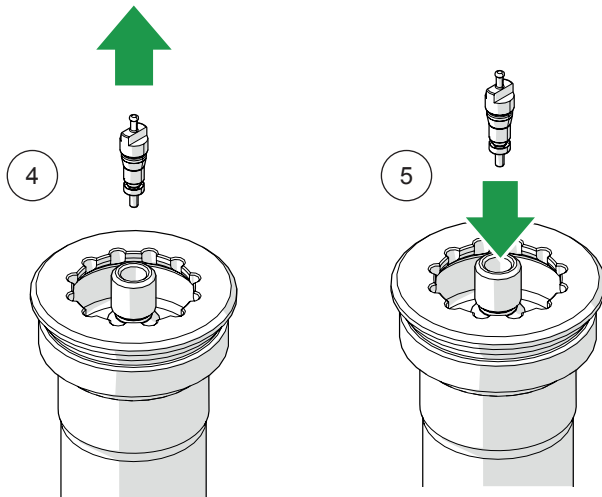

# REBUILD AIR SPRING CARTRIDGE

10. Remove the old air valve schrader (18607-01) from the base cap.

11. Install a new air valve schrader (18607-01) into the base cap.

12. Use a socket wrench with a hex socket 28 mm (18860-01) or a cassette locking tool to remove the top cap.

13. Remove the old o-ring (00338-68) from the top cap. Clean using disc brake cleaner and a paper cloth or rag to remove old thread sealant.

14. Install a new o-ring (00338-68) on the top cap. Apply assembly grease on o-ring.

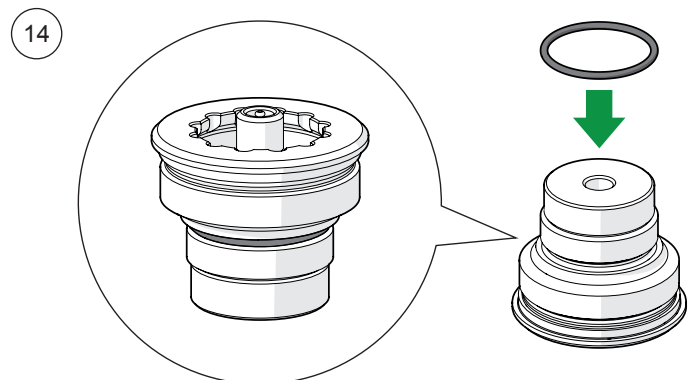
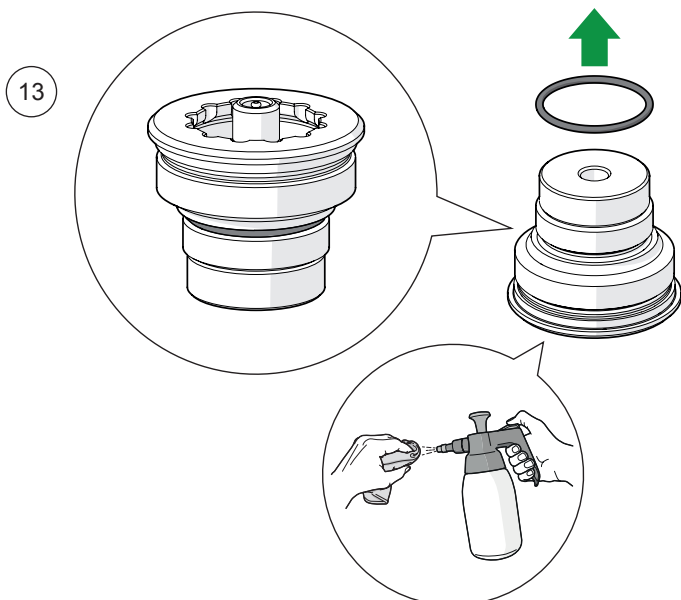
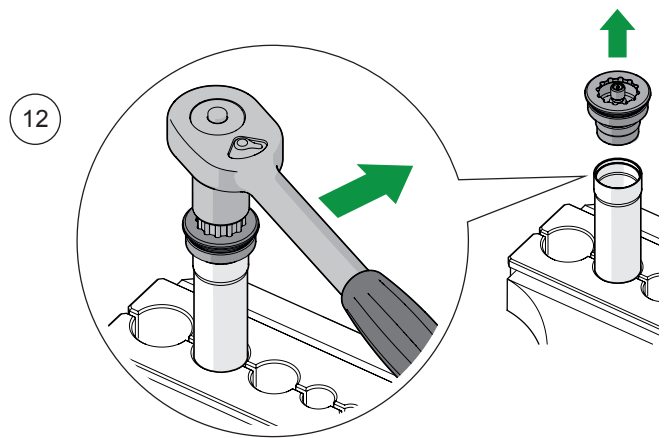
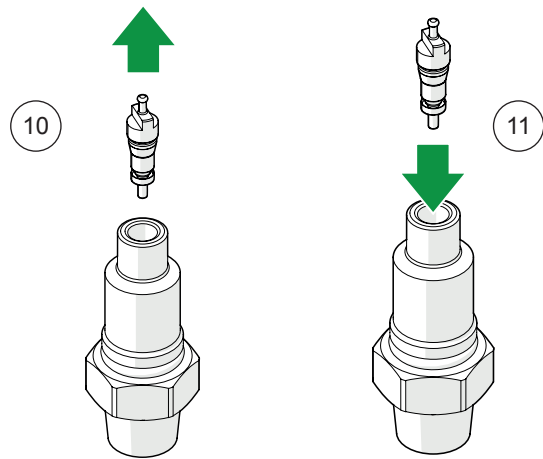

# REBUILD AIR SPRING CARTRIDGE

**15.** Apply a halv turn of Loctite 577 thread sealant (01791-07) to the top cap threads.

**16.** Thread the top cap into the cylinder tube. Use a torque wrench with a 28 mm hex socket or a cassette locking tool to tighten the top cap to 10 Nm.

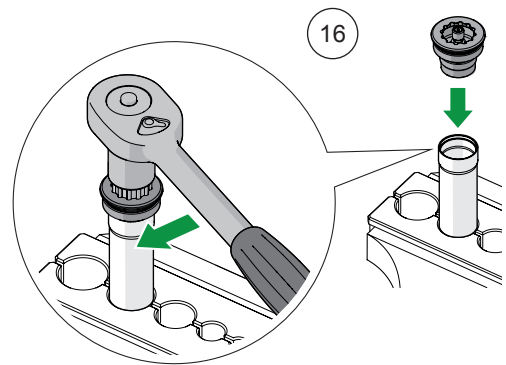
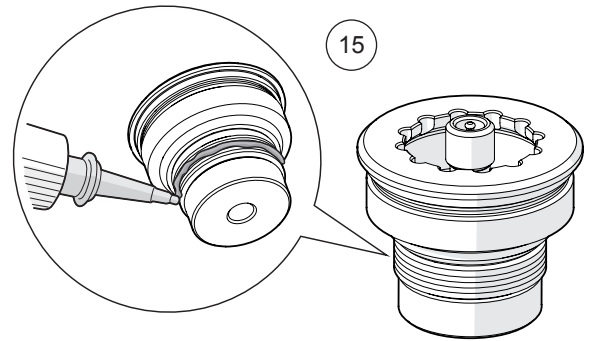

# REBUILD AIR SPRING CARTRIDGE

17. Use a 19/24 mm wrench to loosen the seal head. Slide the cylinder tube off the air spring.

18. Remove the two old o-rings (00638-86) from the upper air chamber cylinder tube.

19. Install two new o-rings (00638-86) on the upper air chamber cylinder tube. Apply assembly grease on o-rings.

20. Remove the old o-ring (18637-01) from the piston.

21. Remove the the two old back-up rings (18556-03).

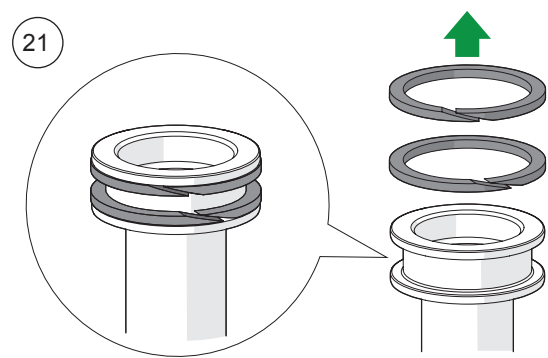
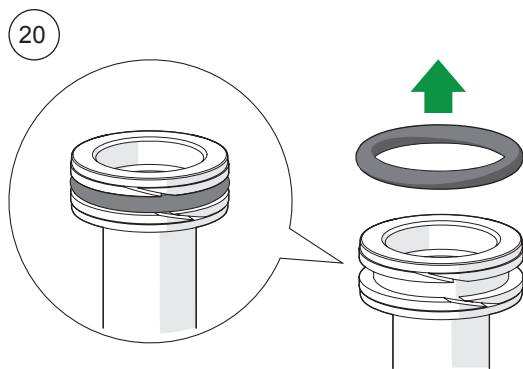
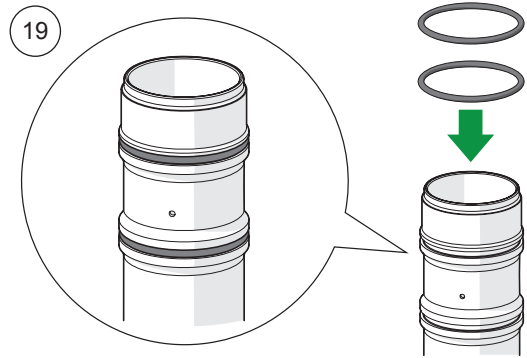
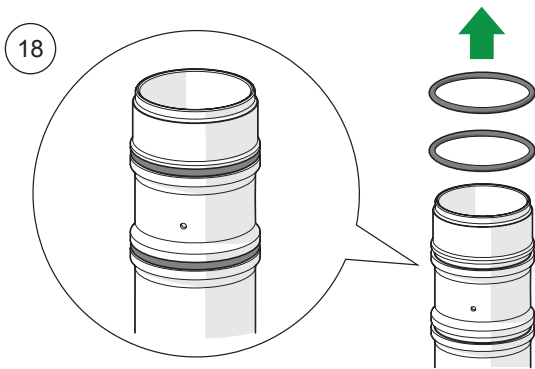
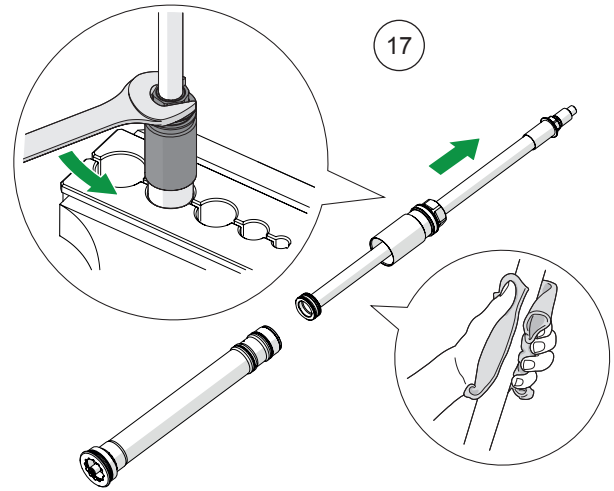

# REBUILD AIR SPRING CARTRIDGE

- 22. Use a 6/8 mm hex wrench to remove the piston.
- 23. Remove the old o-ring (18628-01) from the piston.
- 24. Clean the piston using disc brake cleaner and a paper cloth or rag to remove old grease, thread sealant and dirt.
- 25. Install a new o-ring (18628-01) on the piston.
- 26. Use a 14/16 mm wrench to remove the base cap.

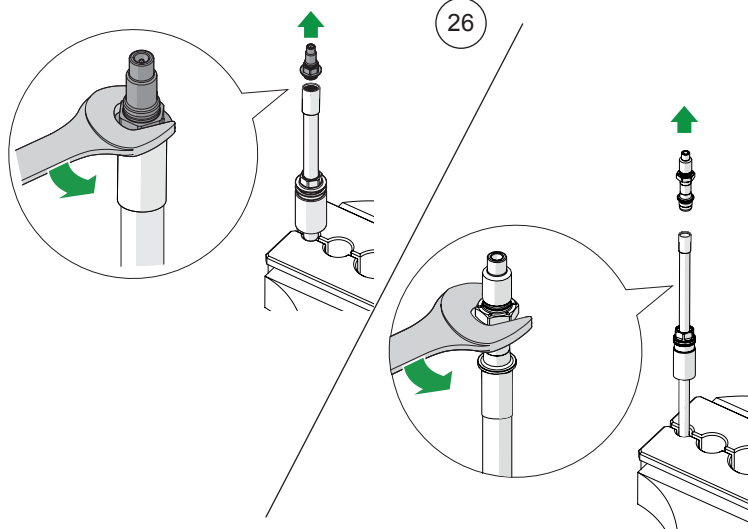
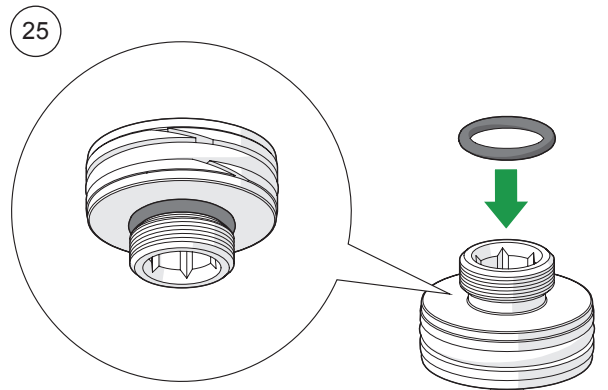
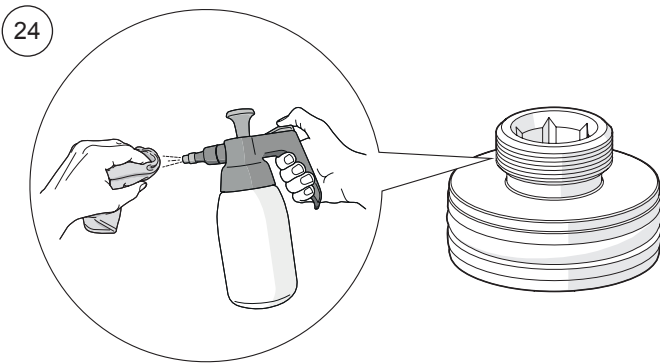
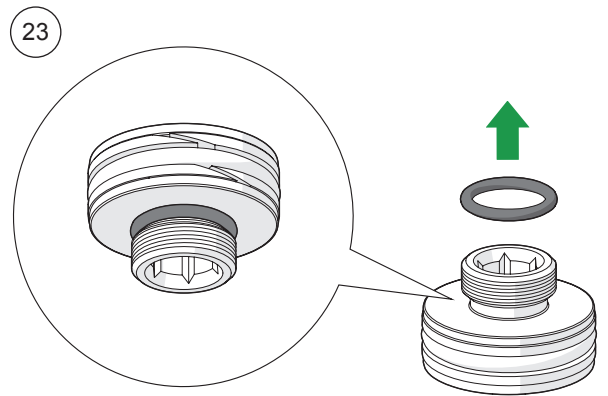
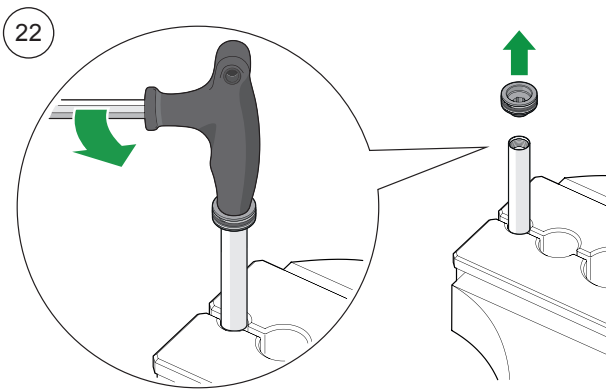

# REBUILD AIR SPRING CARTRIDGE

27. Remove the old o-ring (18628-01) from the base cap.

28. Clean the base cap using disc brake cleaner and a paper cloth or rag to remove old thread sealant.

29. Install a new o-ring (18628-01) on the base cap.

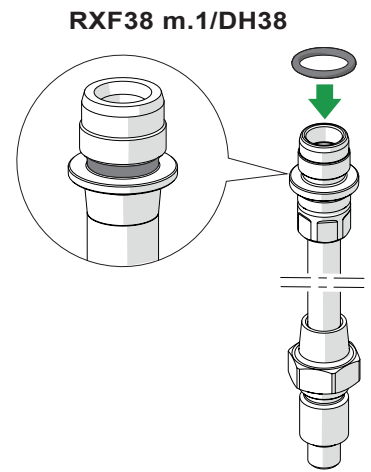
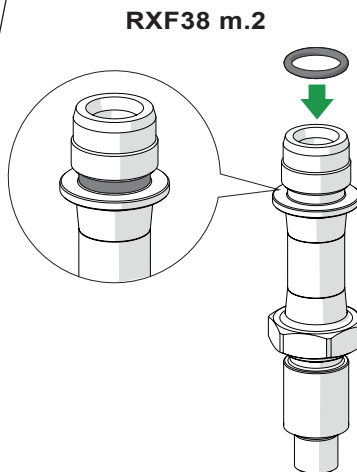
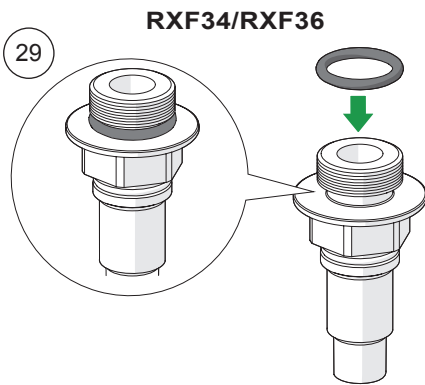
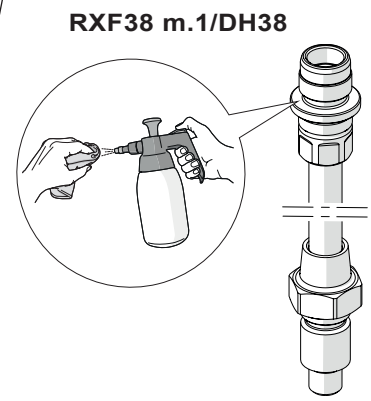
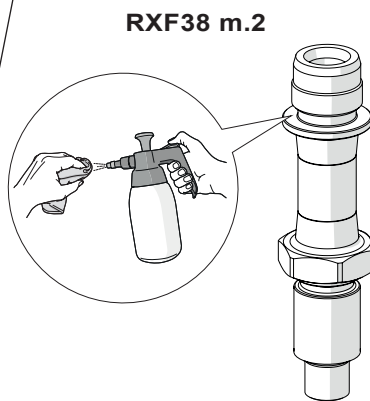
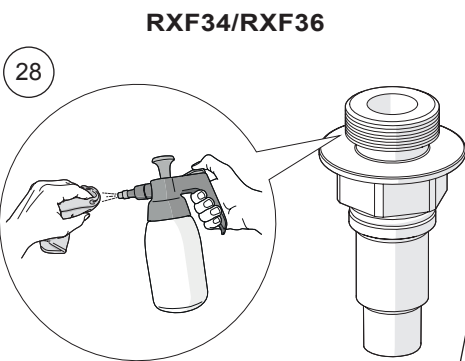
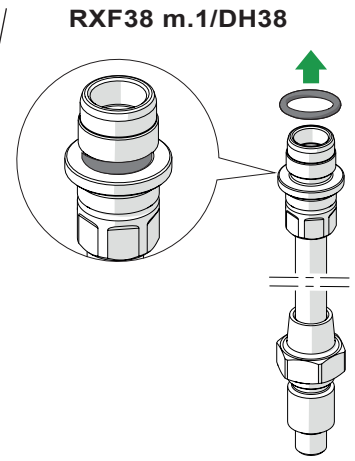
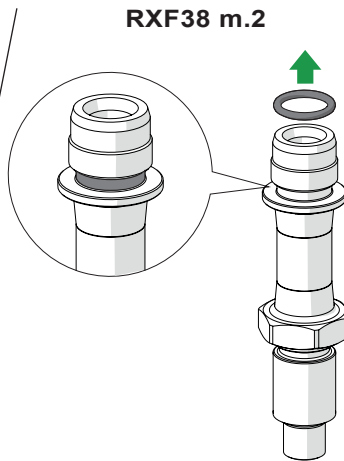
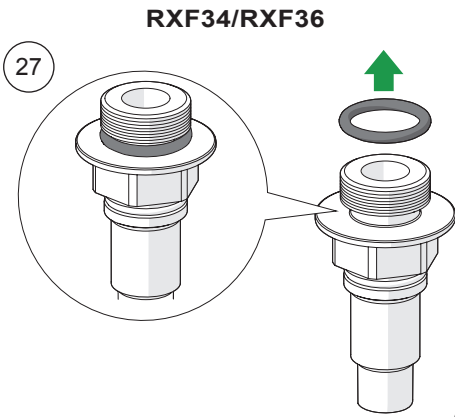

# REBUILD AIR SPRING CARTRIDGE

**Only for DH38/RXf38 m.1 forks!**

**30.** Put the shaft assembly in the multi clamp (Ø8) with the base cap facing upwards and use a 16mm wrench to remove the base cap.

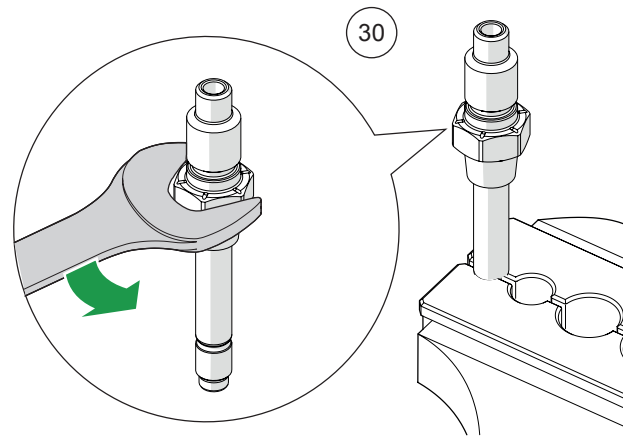

**31.** Turn the shaft assembly upside down and place it in the multi clamp with the seal head facing upwards and use a 12mm wrench to remove the seal head.

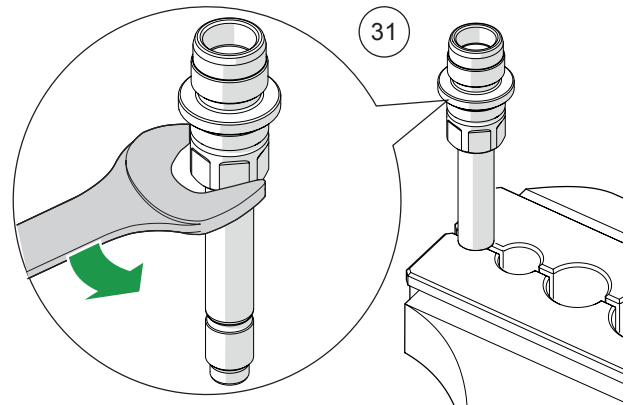

**32.** Remove the old o-ring (00338-39) inside the base cap.

**33.** Clean the threads inside the base cap using disc brake cleaner and a paper cloth or rag to remove thread sealant and dirt.

**34.** Install a new o-ring (00338-39) inside the base cap. Lubricate the o-ring with assembly grease.

**35.** Remove the old o-ring (00338-39) inside the seal head.

**36.** Clean the threads inside the seal head using disc brake cleaner and a paper cloth or rag to remove thread sealant and dirt.

**37.** Install a new o-ring (00338-39) inside the seal head. Lubricate the o-ring with assembly grease.

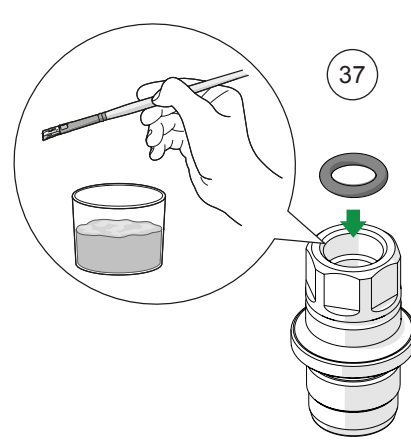
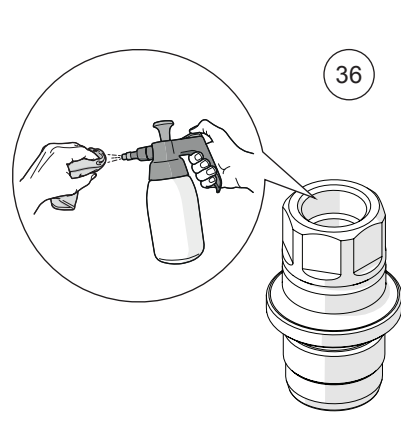
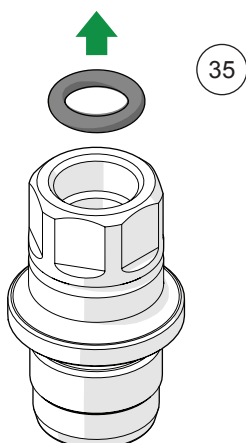
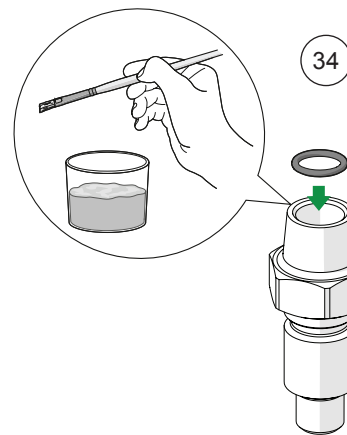
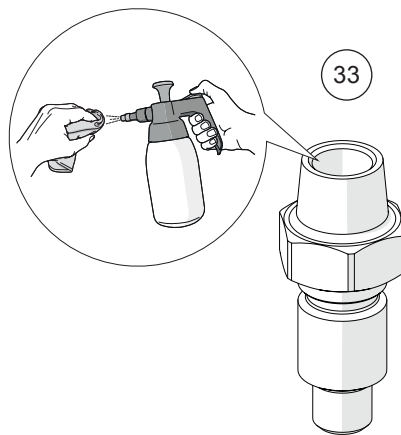
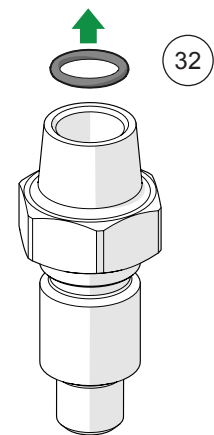



# REBUILD AIR SPRING CARTRIDGE

**38.** Clean the threads on both ends of the shaft using disc brake cleaner and a paper cloth or rag to remove thread sealant and dirt.

**39.** Apply 2 turns of loctite 577 to the threads on one of sides of the shaft.

**40.** Thread the base cap onto the shaft. Use a torque wrench with a 16mm hex socket to tighten the base cap to 8 Nm.

**41.** Apply 2 turns of loctite 577 to the threads on the other side of the shaft.

**42.** Thread the seal head onto the shaft. Use a torque wrench with a 12mm hex socket to tighten the base cap to 8 Nm.

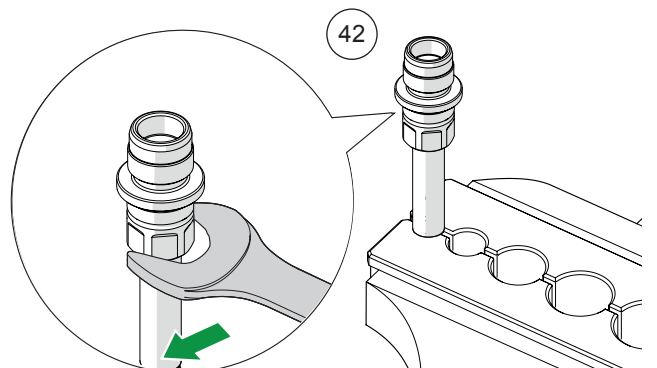
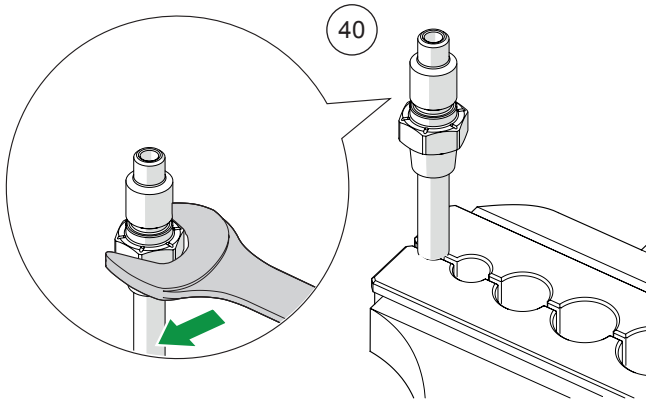
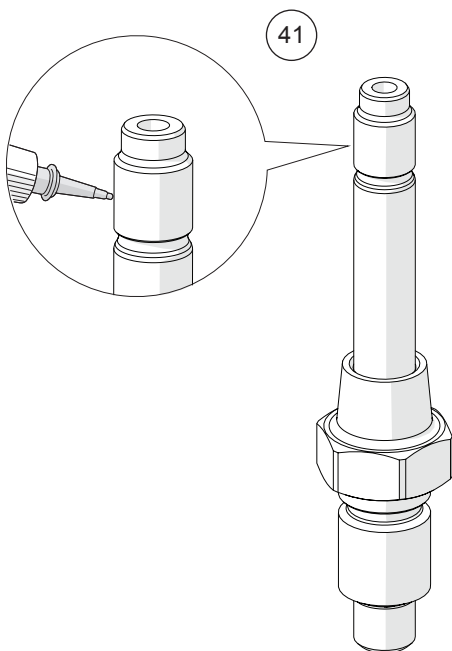
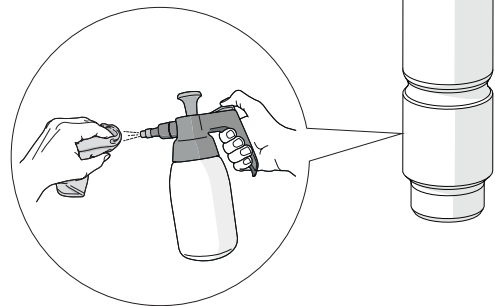
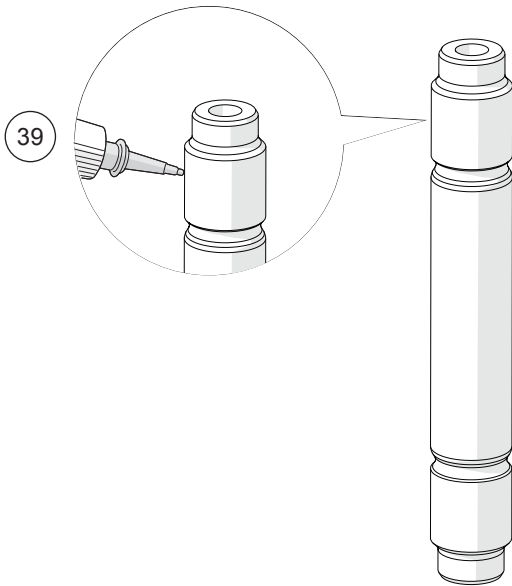
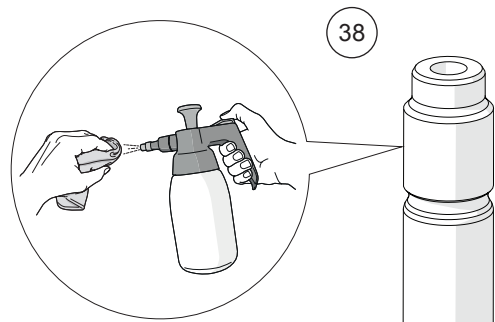

# REBUILD AIR SPRING CARTRIDGE

43. Remove the seal head from the cylinder tube.

44. Remove the old backup ring (18641-01) from inside the seal head.

45. Remove the old x-ring (18639-01) from inside the seal head.

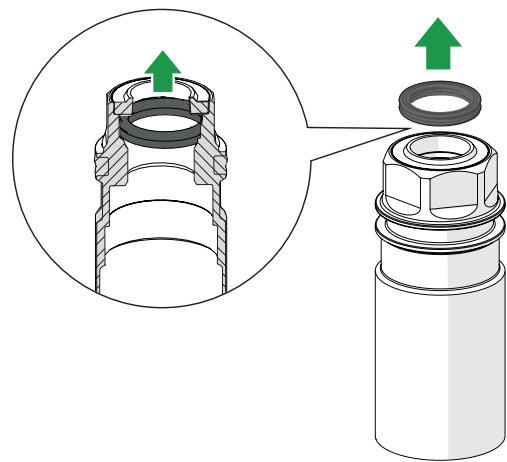
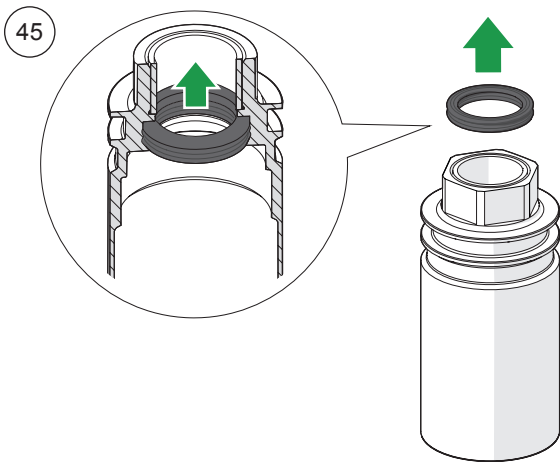
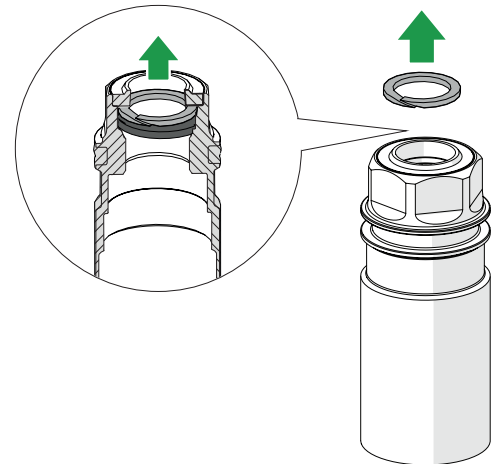
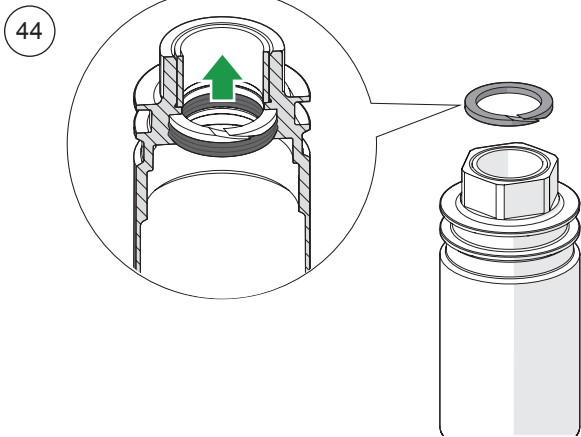
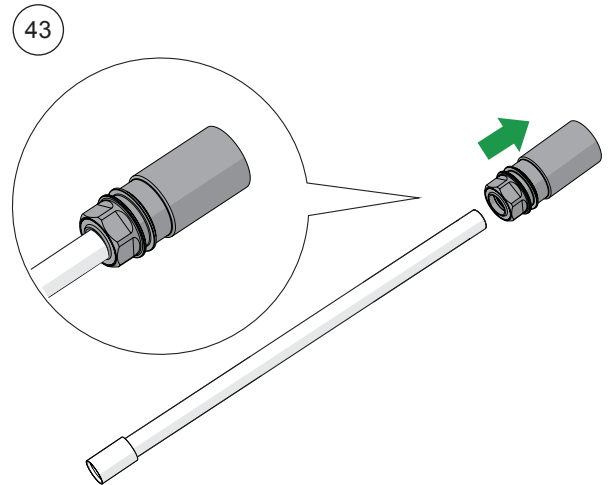

# REBUILD AIR SPRING CARTRIDGE

46. Apply function grease on the new x-ring.

47. Install the new x-ring (18639-01) inside the seal head.

48. Install a new backup ring (18641-01) inside the seal head.

49. Remove the third chamber piston and the bump rubber from the cylinder tube. Stick a long rod or similar in the other end of the cylinder to push them out.

50. Remove the x-ring (18629-02) from the third chamber piston.

51. Apply function grease on the new x-ring.

52. Install the new x-ring (18629-02) on the third chamber piston.

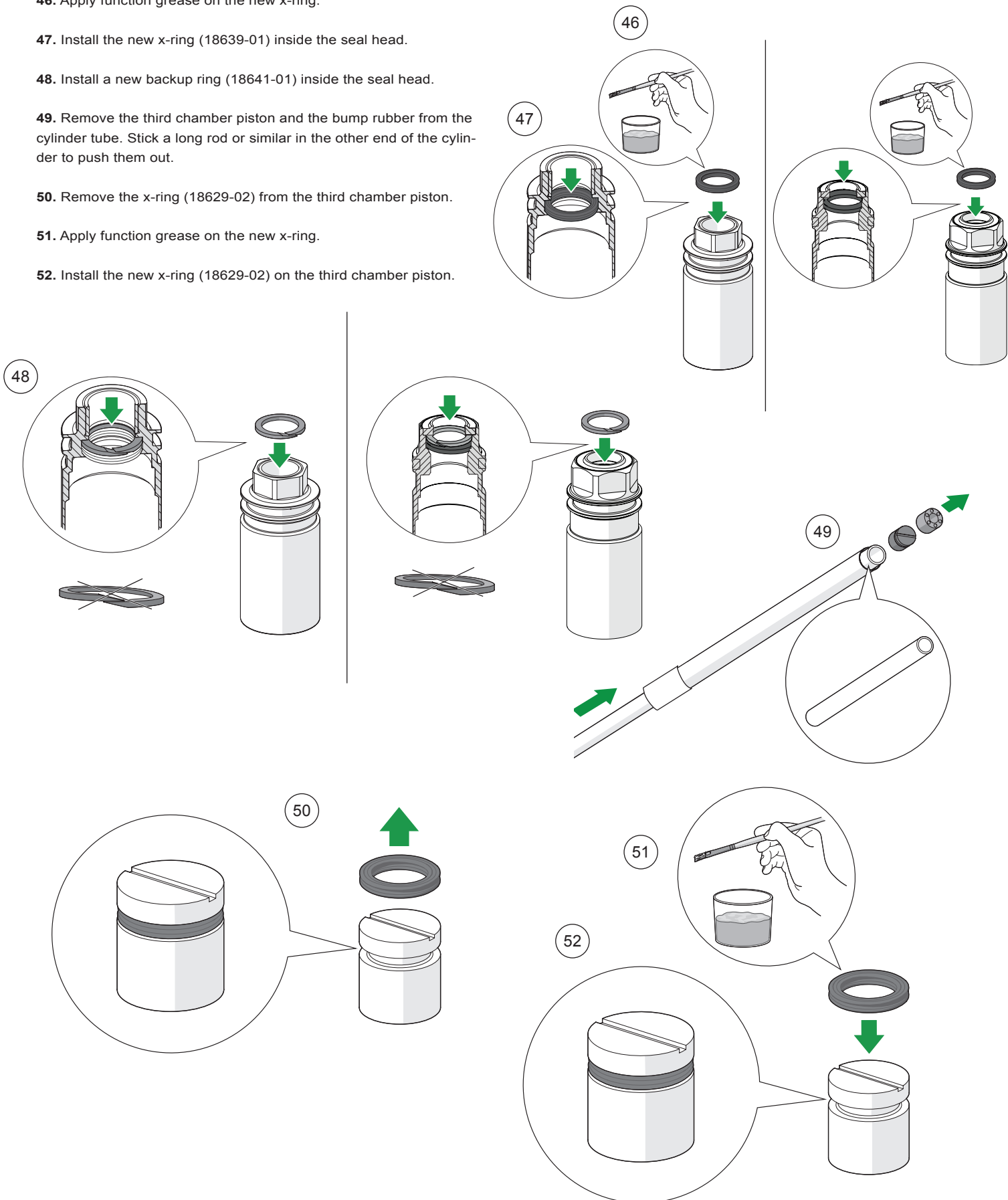

# REBUILD AIR SPRING CARTRIDGE

**53.** Apply a half turn of Loctite 577 thread sealant to the base cap threads (cylinder side). Lubricate the o-ring (18628-01) with assembly grease.

**54.** Thread the base cap into the cylinder tube. Use a torque wrench with a 14/16 mm hex socket to tighten the base cap to 8 Nm.

**55.** Use the Mounting sleeve shaft 14/8 tool (18860-03) to prevent damages to the x-ring and support ring in the seal head when sliding through the cylinder tube.

**56.** Reinsert the third chamber piston and a new bump rubber (18649-01) into the cylinder tube.

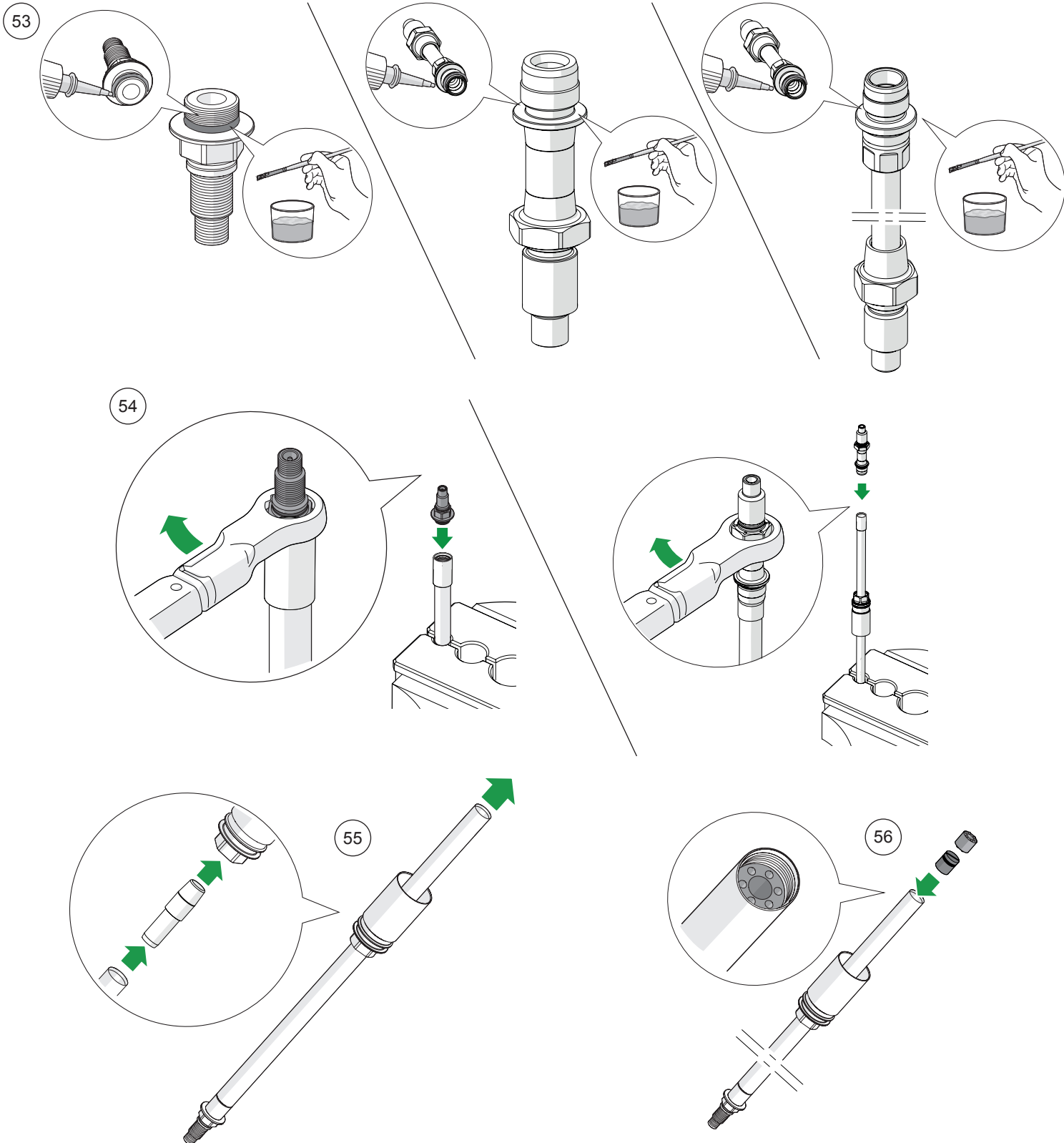

# REBUILD AIR SPRING CARTRIDGE

**57.** Apply a half turn of Loctite 577 thread sealant to the piston threads. Lubricate the o-ring (18628-01) with assembly grease.

**58.** Thread the piston into the cylinder tube. Use a torque wrench with a 6/8 mm hex socket to tighten the piston to 8 Nm.

**59.** Carefully clean the piston using disc brake cleaner and a paper cloth or rag to remove old grease and dirt.

**60.** Install two new back-up rings (18556-03) on the piston.

**61.** Install a new o-ring (18637-01) on the piston between the back-up rings.

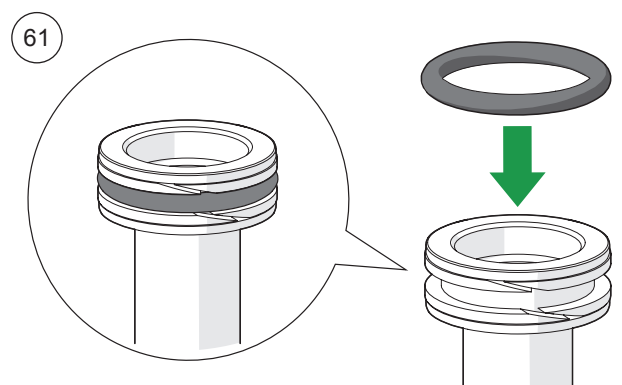
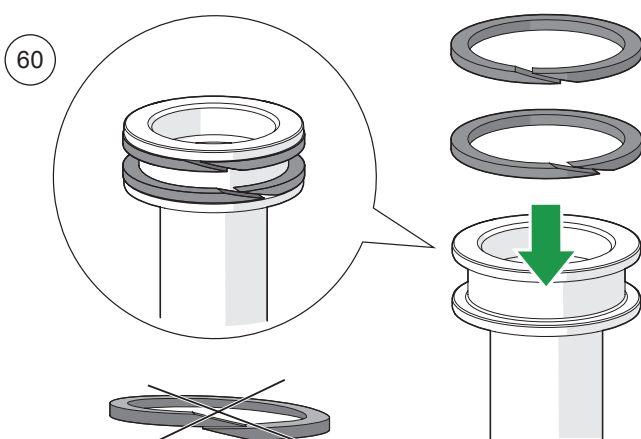
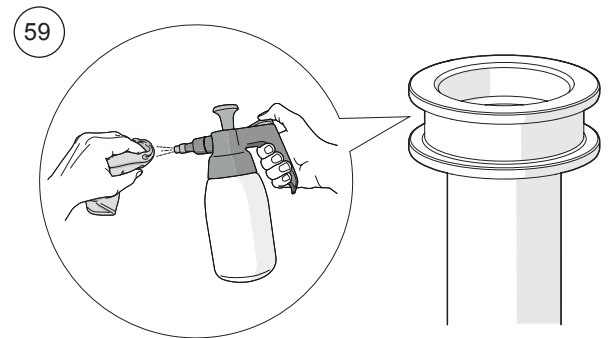
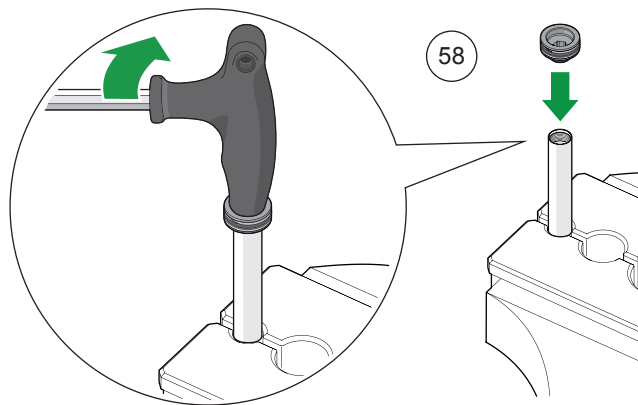
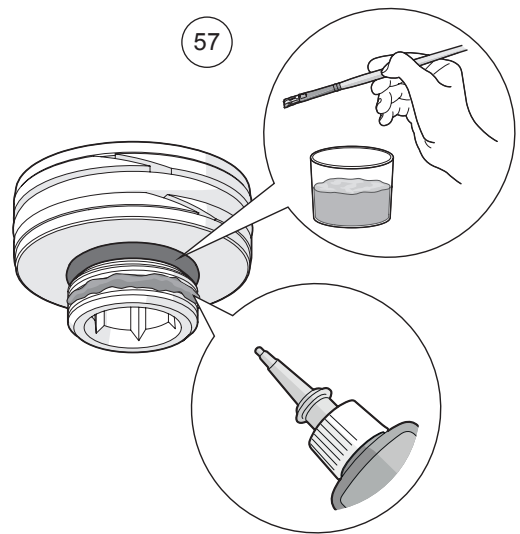

# REBUILD AIR SPRING CARTRIDGE

**62.** Apply 2 ml of function grease at the inside of the cylinder tube (smeared around). Add 0,5 ml of air spring lubrication fluid distributed on top of the grease.

**63.** Apply a thin layer of function grease on the o-ring and the back-up rings on the main piston.

**64.** Insert main piston in the cylinder tube and add 0,5 ml of air spring lubrication fluid inside the cylinder tube. Slide the seal head onto the cylinder tube and screw them together hand-tight.

**65.** Use a 19/24 mm torque wrench to tighten the seal head to 10 Nm.

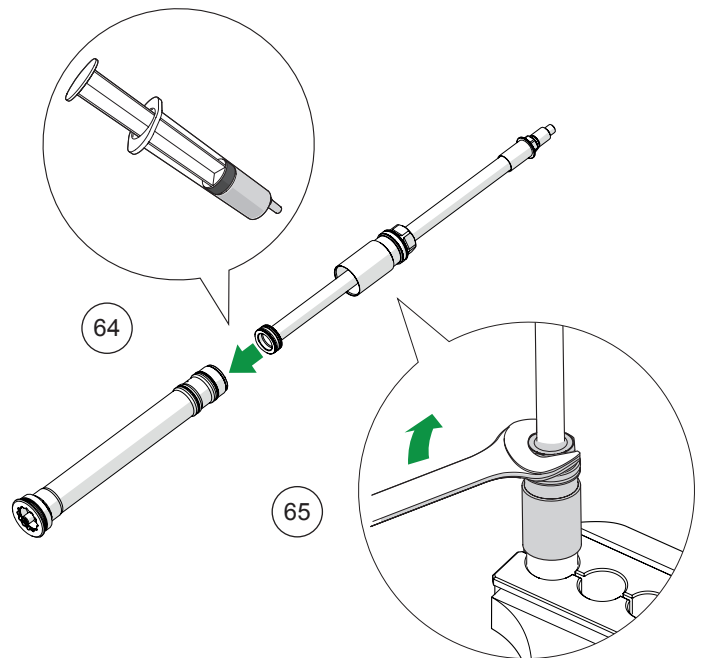
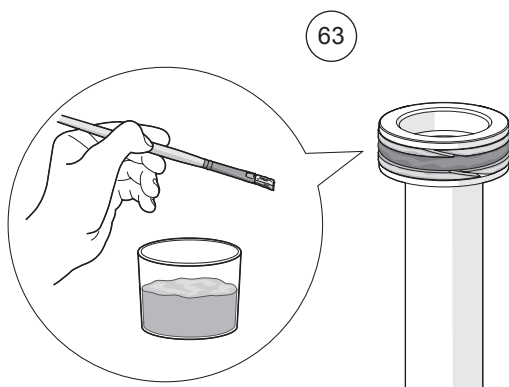
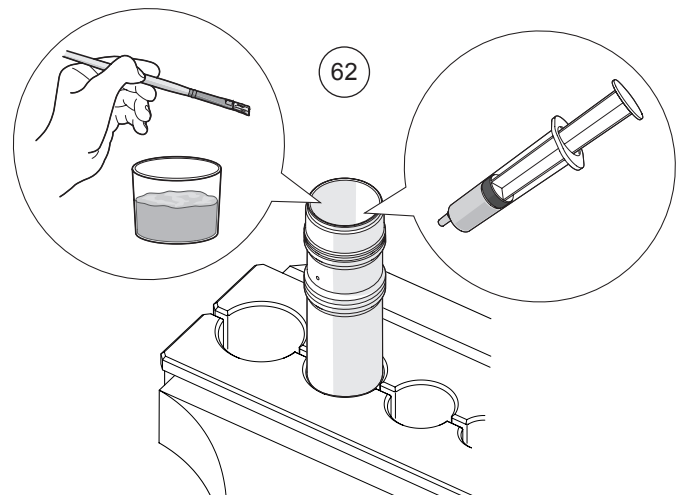

# REBUILD AIR SPRING CARTRIDGE

## Reinstall air spring cartridge (RXF34/RXF36/RXF38)

### 👁 Note!

If the 28 mm hex socket was used to loosen the top cap perform step 66 applying loctite. Skip step 66 if the cassette lock ring tool was used since the top cap has preapplied loctite.

66. Apply blue Loctite 243 to the first (lower) two (2) threads of the top cap (male).

67. Reinstall the Air spring cartridge into the stanchion tube.

68. Use a torque wrench with a 28 mm hex socket (18860-01) or a cassette locking tool to tighten the top cap to 32 Nm.

### ⚠ Caution!

Do not use an adapter between wrench and socket, as this will increase the risk of damaging the anodized finish of the top cap.

69. Wipe off eventual excessive Loctite 243.

### Important!

Leave the Loctite to cure for 24 hours before riding.

70. Refit the lower valve nut and the washer (for M10 nut). Use a torque wrench with a 12/14mm hex socket to tighten the nut.

Torque: 10 Nm

71. Inflate the ramp up chamber (A) at the bottom and then the positive air chamber (B) at the top to the desired air pressures.

### ⚠ Caution!

Inflate the ramp up chamber (A) at the bottom first.

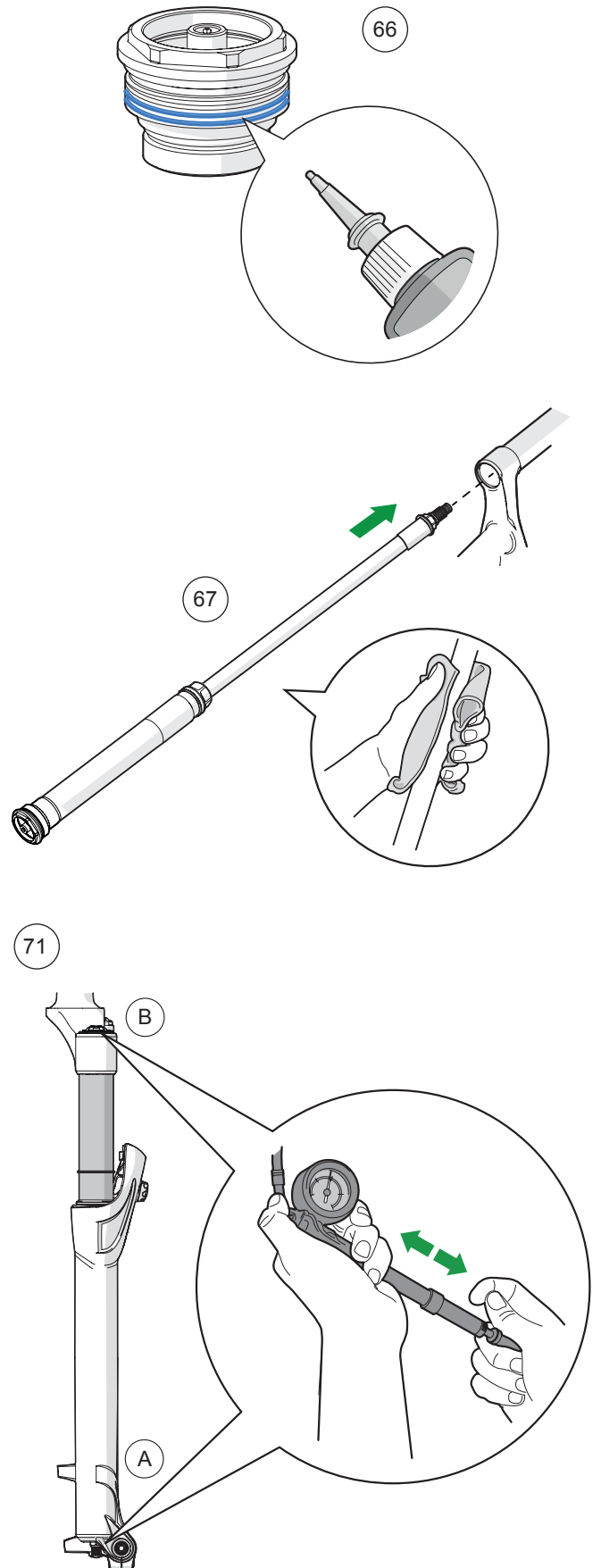
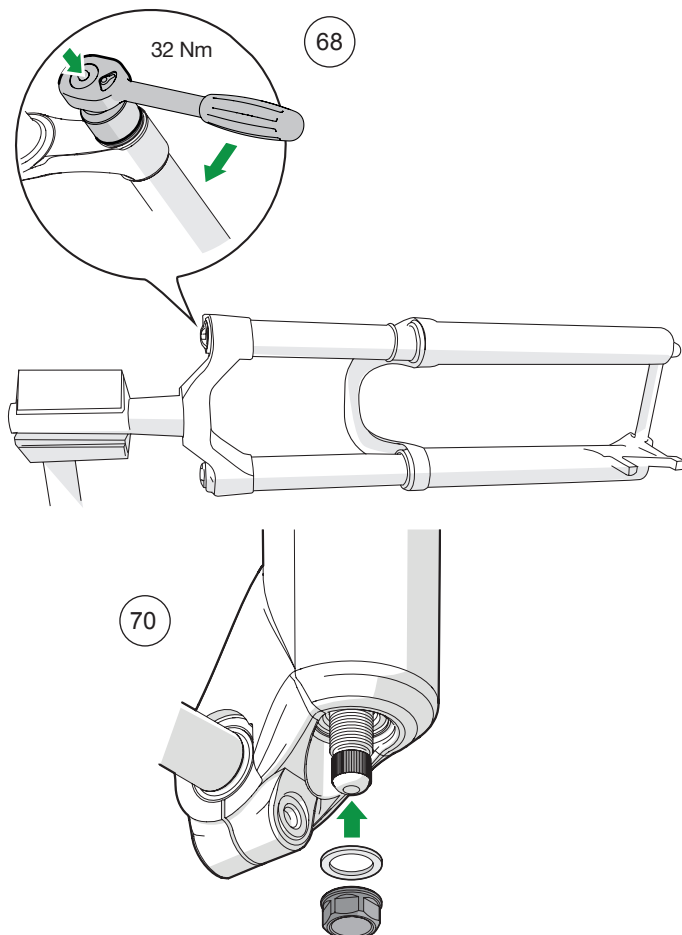

# REBUILD AIR SPRING CARTRIDGE

## Reinstall Air spring cartridge (DH38)

1. Inflate the ramp up chamber (A) at the bottom and the positive air chamber (B) at the top to the desired air pressures.

### ⚠ Caution!

*Inflate the ramp up chamber (A) at the bottom first.*

### 👁 Note!

*If no pre-applied Loctite is found on the top cap perform step 2.*

*If the top cap has pre-applied Loctite continue to step 3.*

2. Apply blue Loctite 243 to the first (lower) two (2) threads of the top cap (male).

3. Reinstall the Air spring cartridge into the stanchion tube.

4. Use a torque wrench with a 28 mm hex socket (18860-01) to tighten the top cap to 32 Nm.

### ⚠ Caution!

*Do not use an adapter between wrench and socket, as this will increase the risk of damaging the anodized finish of the top cap.*

5. Wipe off eventual excessive Loctite 243.

### Important!

*Leave the Loctite to cure for 24 hours before riding.*

6. Reinstall the base cap nut. Use a torque wrench with a 14 mm hex socket to tighten the nut. Torque: 10 Nm.

7. Reinstall the air spring knob, air valve cap and the bash cap.

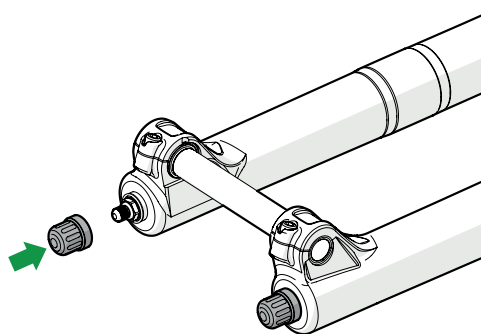
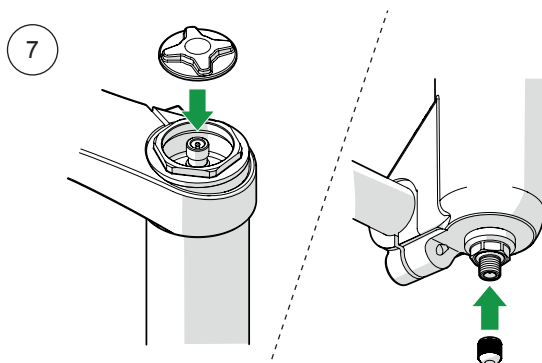
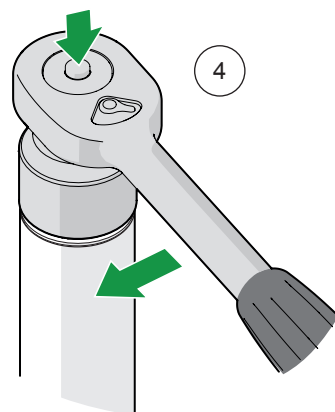
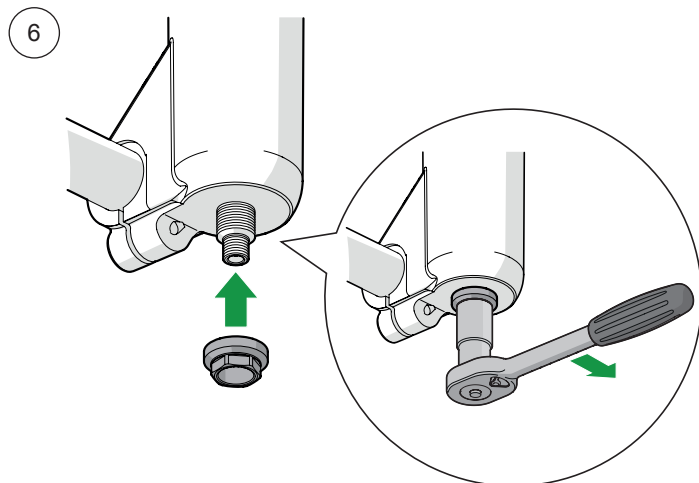
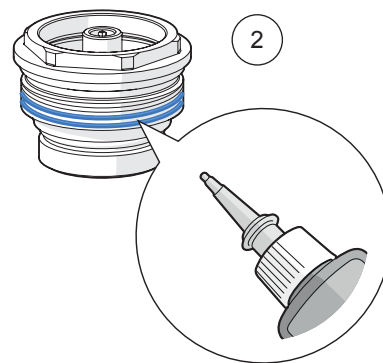
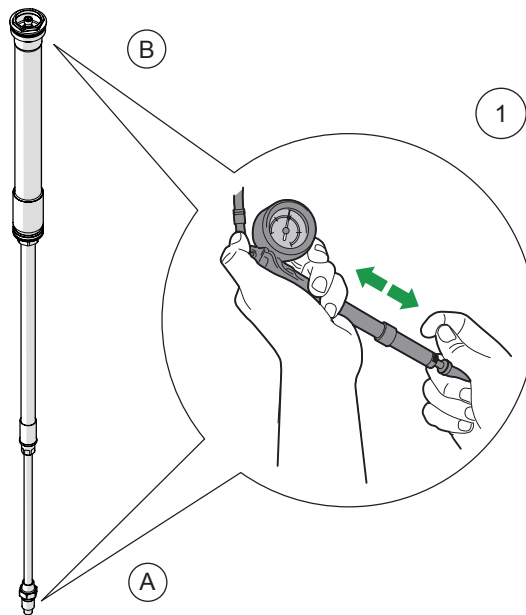



# REBUILD AIR SPRING CARTRIDGE

## Appendix A

Part no of the fork can be found at the bottom of the steering tube.

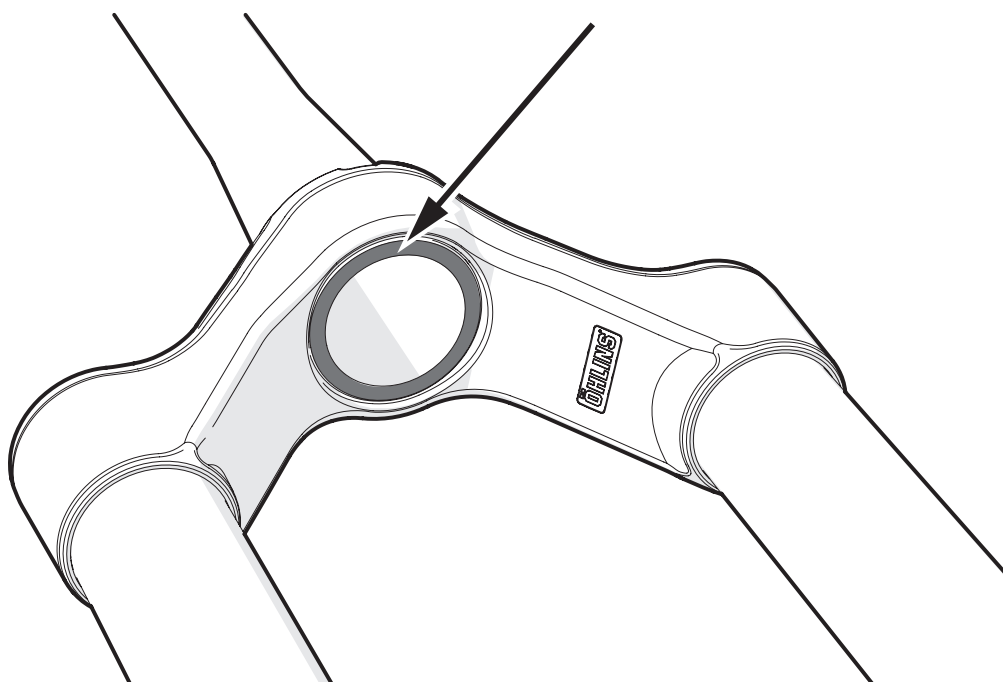

# REBUILD AIR SPRING CARTRIDGE

Your Öhlins retailer:

Öhlins Racing AB  
Box 722  
SE-194 27, Upplands Väsby  
Sweden

Phone: +46 (0)8 590 025 00  
Fax: +46 (0)8 590 025 80  
[www.ohlins.com](http://www.ohlins.com)



[www.ohlins.com](http://www.ohlins.com)