

Front Fork

RXF34 m.2/RXC34 m.1

Workshop Manual - Chassis and Air Spring 100 h service



SAFETY PRECAUTIONS

General Warnings

Note!

When working with the Öhlins product, always read the Vehicle Service Manual.

Note!

The shock absorber/front fork/steering damper is an important part of the vehicle and will affect the stability.

Note!

Read and ensure you understand the information in this manual and other technical documents provided by Öhlins, before using or servicing the product.

Note!

Öhlins Racing AB can not be held responsible for any damage to the shock absorber/front fork/steering damper, vehicle, other property or injury to persons, if the instructions for mounting, usage and maintenance are not followed exactly.

Warning!

After installing the Öhlins product, take a test ride at low speed to ensure your vehicle has maintained stability.

Warning!

If the suspension makes an abnormal noise, or the function is irregular, or if you notice any leakage from the product, stop the vehicle immediately and return the product to an Öhlins Service Centre.

Warning!

The product warranty shall only apply if the product has been operated and maintained in accordance with recommendations in this manual. If you have any questions regarding usage, service, inspection and/or maintenance please contact Öhlins.

Note!

Before working on the product make sure that the vehicle is washed and cleaned properly. Do not use alcobased products on the outside or inside of the product.

Product Specific Warnings

Warning!

This product was developed and designed exclusively for a specific vehicle model and shall only be installed on the intended vehicle model in its original condition as delivered from the vehicle manufacturer.

Warning!

This product is pressurized. Do not open, service or modify this product without proper education (authorized Öhlins dealer/distributor) and proper tools.

Caution!

Do not use a pressure washer or a power washer when cleaning the fork.

Table of Contents

Tools	3
Overview - General layout	3
Chassi 100-Hour Service	5
Air spring Cartridge 100-hour service	9
Appendix A. RXF34 m.2/ RXC34 m.1	16
Appendix B. RXC34 m.1 Carbon	17

SAFETY SYMBOLS

In this manual, mounting instructions and other technical documents, important information concerning safety is distinguished by the following symbols:



The Safety Alert Symbol means: Warning! Your safety is involved.

Warning!

The Warning Symbol means: Failure to follow warning instructions can result in severe or fatal injury to anyone working with, inspecting or using the shock absorber/front fork, or to bystanders.

Caution!

The Caution Symbol means: Special precautions must be taken to avoid damage to the shock absorber.

Note!

The Note Symbol indicates information that is important regarding procedures.

© Öhlins Racing AB. All rights reserved.

Any reprinting or unauthorized use without the written permission of Öhlins Racing AB is prohibited.

RXF34 M.2/RXC34 M.1 FRONT FORK 100 H SERVICE

Tools

1	19246-03	Wiper seal tool 34
2	-	Cassette locking tool

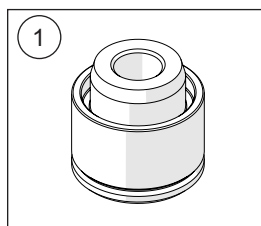

Oil, grease

Damper fluid	01309-01 - High performance suspension fluid 1L
Fork lubrication fluid	01336-01 - Renep CGLP 68 Fork lube 1L
Air spring lubrication fluid	01337-06 - Renep CGLP 220 Air spring lube 0.6L
Function grease	01338-22 - Renolit SI 410 M Silicone grease 225g
Assembly grease	Slickoleum / Buzzy's Slick Honey

Overview - General layout

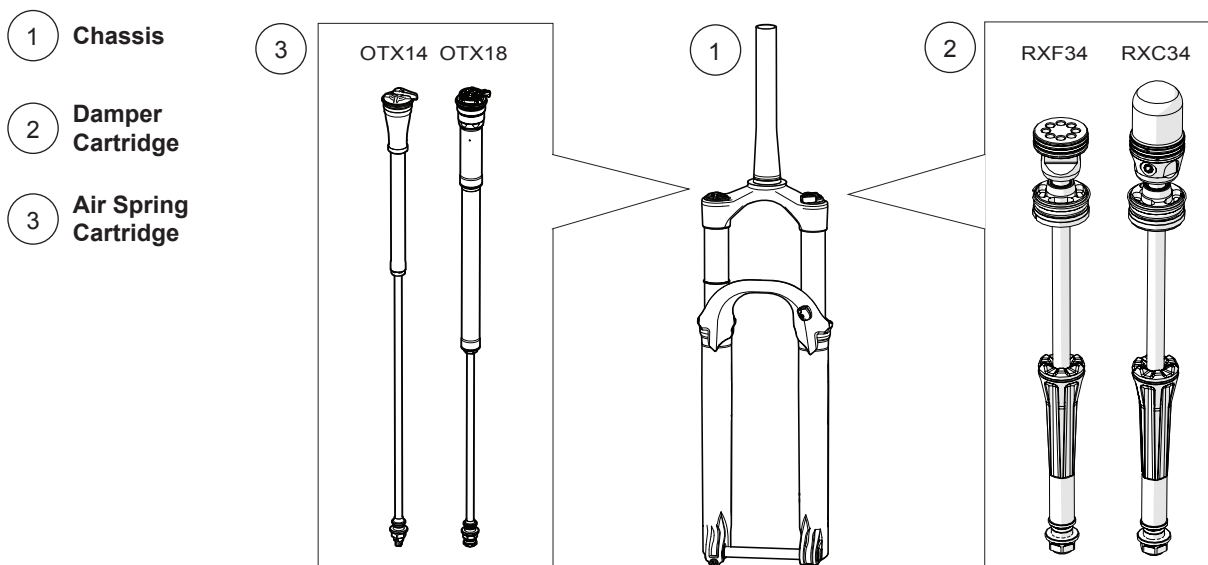

RXF34 M.2/RXC34 M.1 FRONT FORK 100 H SERVICE

Service kit contents

1	19542-01	Service kit chassis RFX34
2	19547-01	Air spring 31 RFX 34 100 h service kit

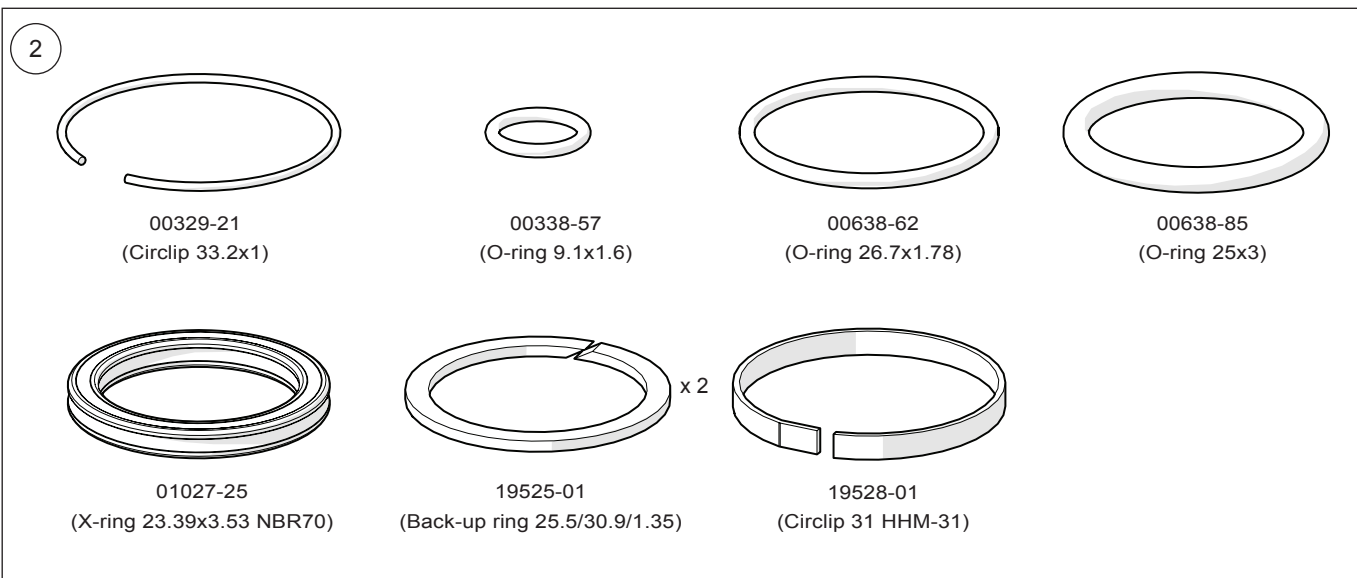
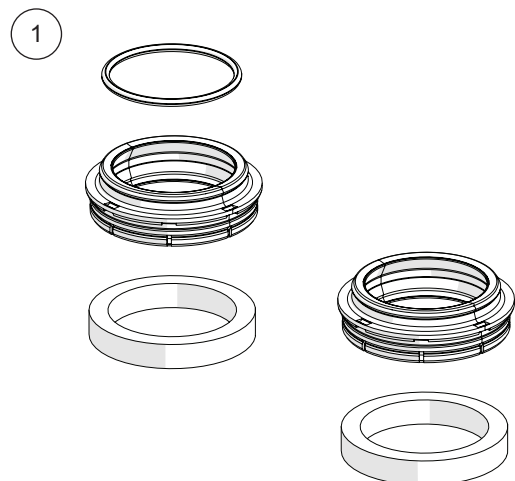

RXF34 M.2/RXC34 M.1 FRONT FORK 100 H SERVICE

Chassi 100-Hour Service

Note!

Record the rebound adjuster setting and the pressure in the positive air chamber before service. We recommend using a bike stand to clamp the steering tube when working on the fork.

1. Thoroughly clean the outside of the fork from dirt or grit.
2. Release all the air from the main chamber and the negative chamber by holding the fork extended in the transfer position. Tip! When almost all air is released from the spring, let go of the lower and let it compress about 30 mm until all the pressure is gone. This will help with getting the seal head out.
3. Measure and record LSC, HSC and Rebound clicks.
4. **Applies for RXF34 only:** Use a 14 mm wrench to hold back the rebound adjuster knob steady. With a 2 mm hex wrench remove the screw and the knob.
5. Remove the nut on both sides by using a socket wrench with a 14 mm deep hex socket.
6. Slide the lower legs off the stanchions.
7. Drain the lower legs of all fluids.

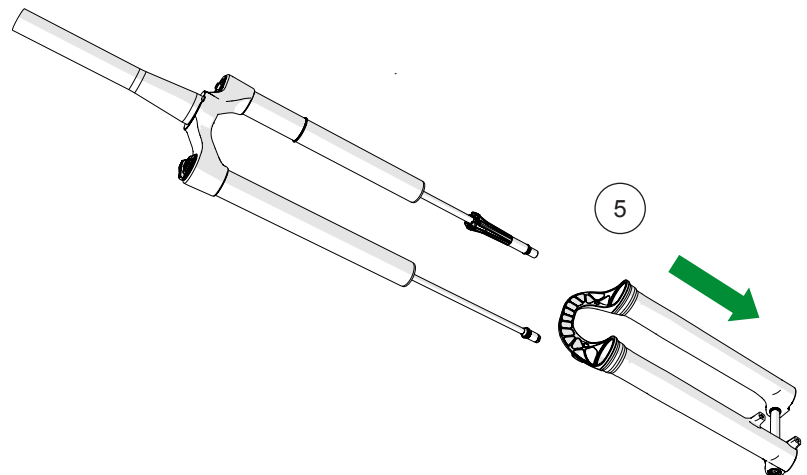
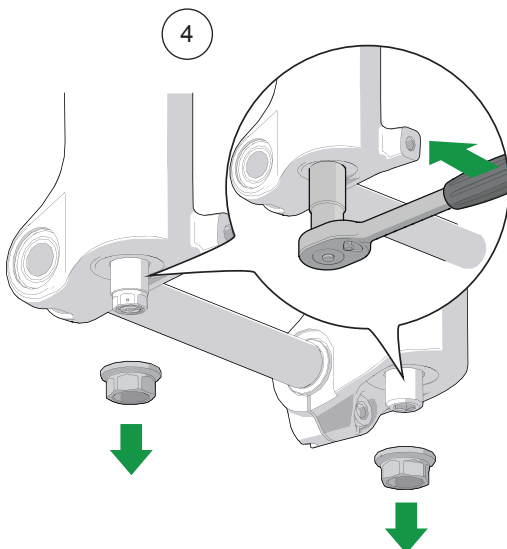
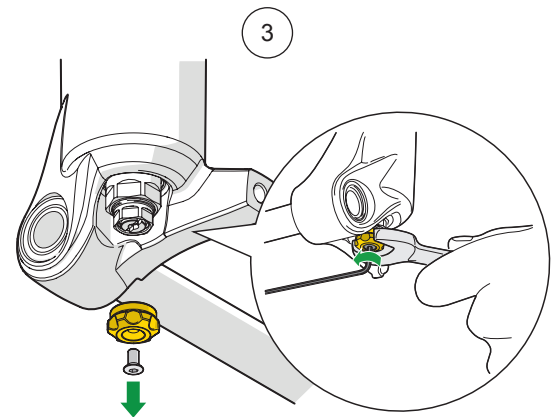
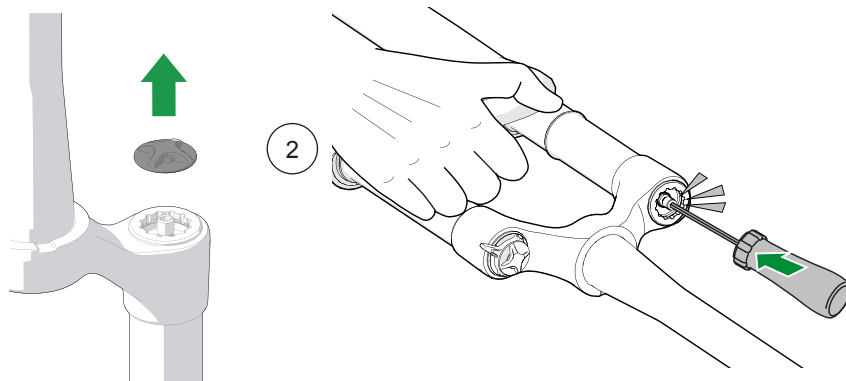
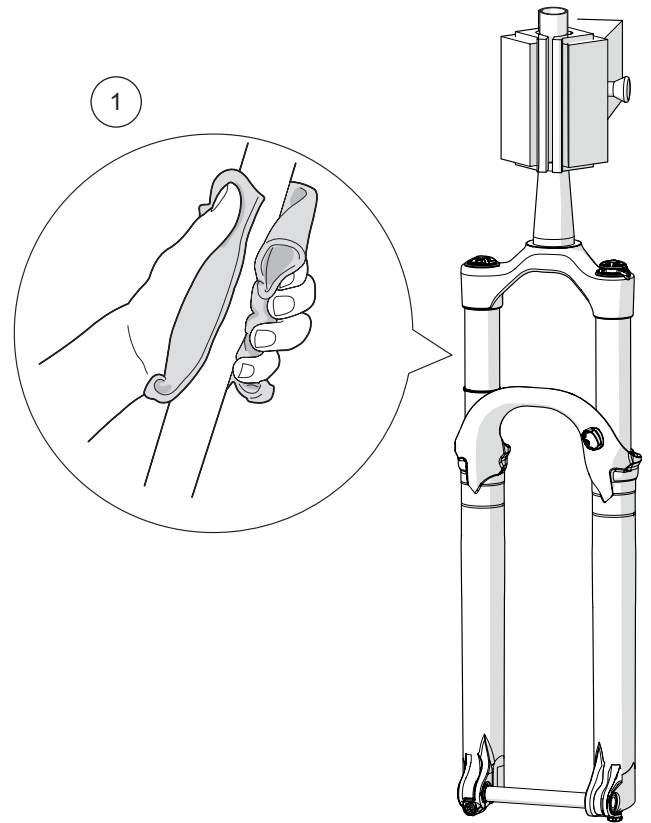

RXF34 M.2/RXC34 M.1 FRONT FORK 100 H SERVICE

8. Use tweezers to cautiously remove the foam rings in the lower legs.

9. Soak the new foam rings in fresh fork lubrication fluid.

10. Use a screwdriver or similar to remove the old wiper seals.

Note!

Be careful not to scratch the bushings or sealing surfaces in the lowers.

11. Use a rag wrapped around a long rod or similar to clean the insides of the lower legs.

Note!

Be careful not to scratch the bushings.

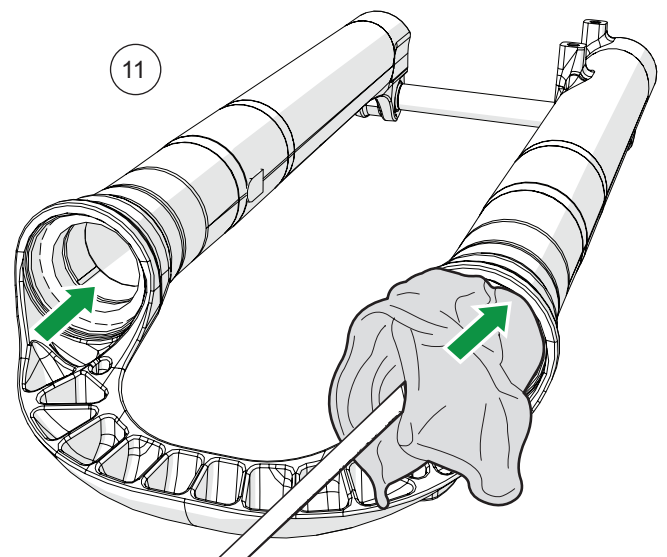
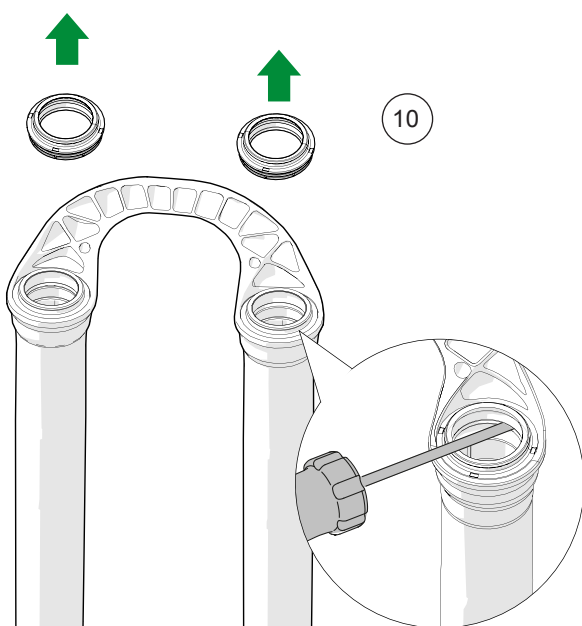
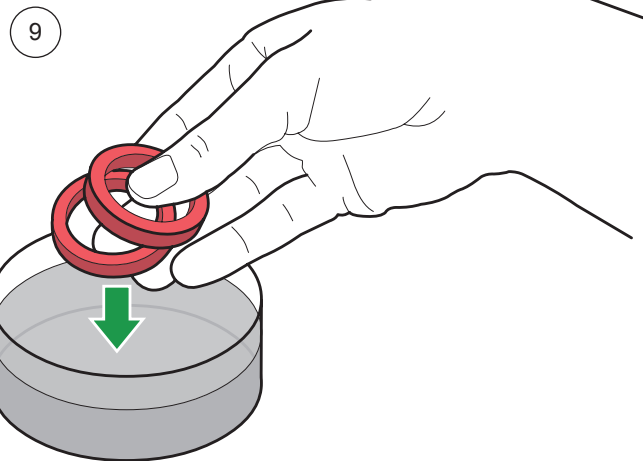
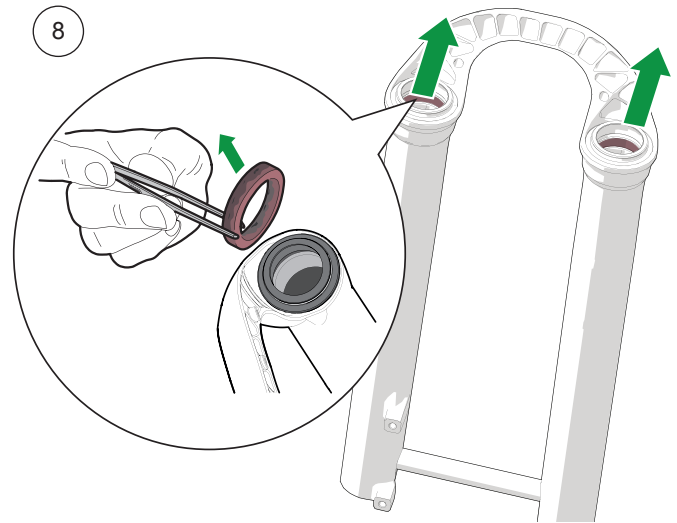

RXF34 M.2/RXC34 M.1 FRONT FORK 100 H SERVICE

12. Carefully clean the wiper seal and foam ring areas using disc brake cleaner and a paper cloth or rag to remove old suspension fluid and dirt.

13. Reinstall new wiper seals into the lower legs. Use the wiper seal tool and a soft hammer to put them in place.

14. Use tweezers to carefully insert the soaked foam rings into the lower legs. Check that they are mounted correctly and not twisted.

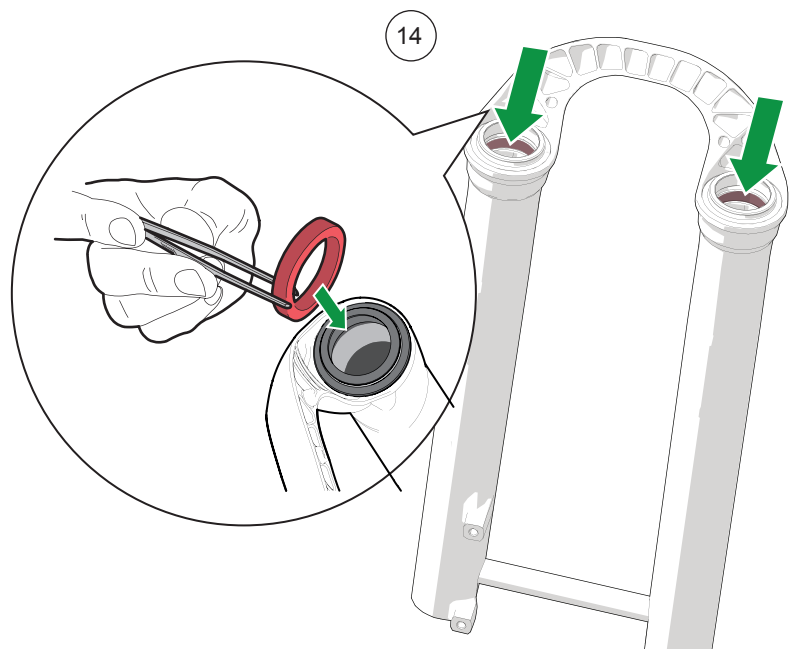
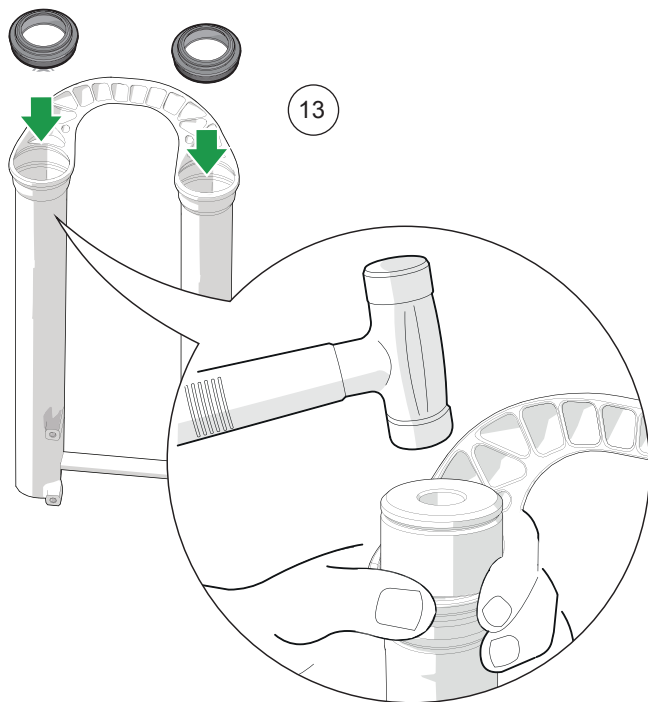
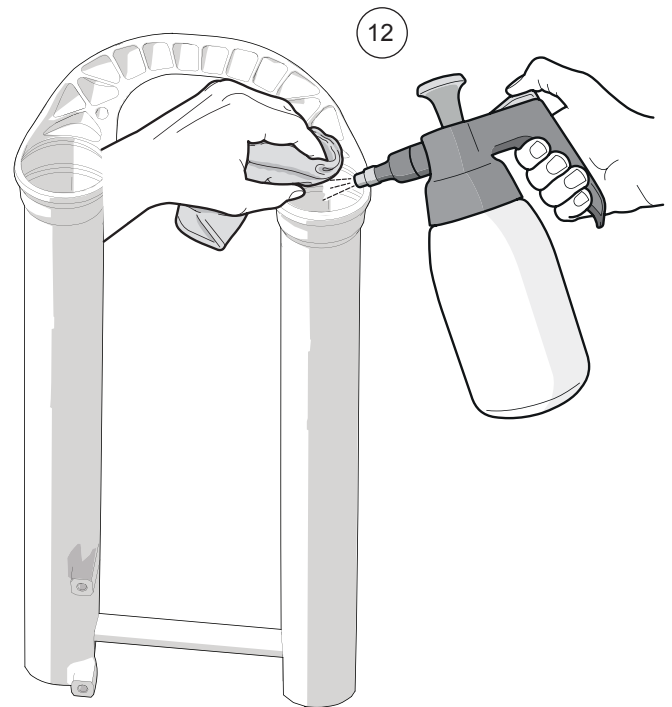

RXF34 M.2/RXC34 M.1 FRONT FORK 100 H SERVICE

15. Hold the lower legs upside down and use a soft rag inside the wiper seals to wipe of any oil residues from previous step.

16. Apply a thin layer of function grease to the inner surfaces of the wiper seals.

17. Remove the old sag o-ring.

18. Install a new sag o-ring from the service kit.

19. Clean the stanchion tubes with a paper cloth or soft rag.

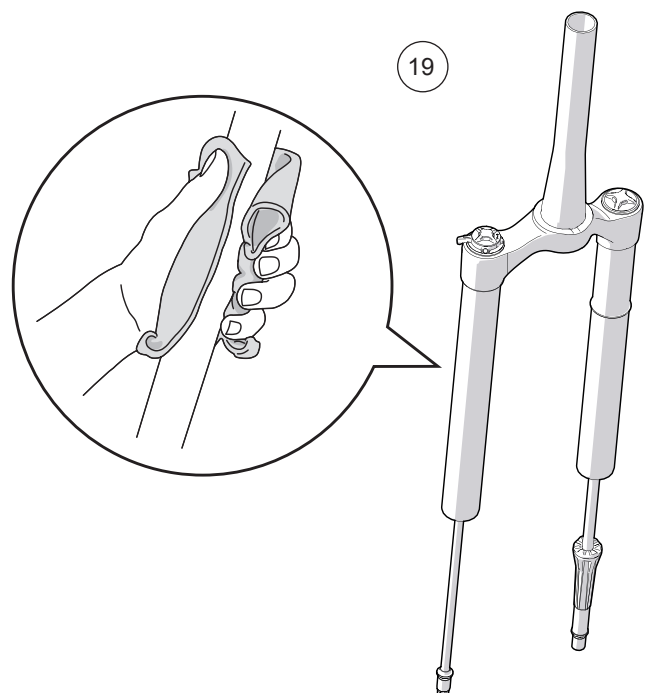
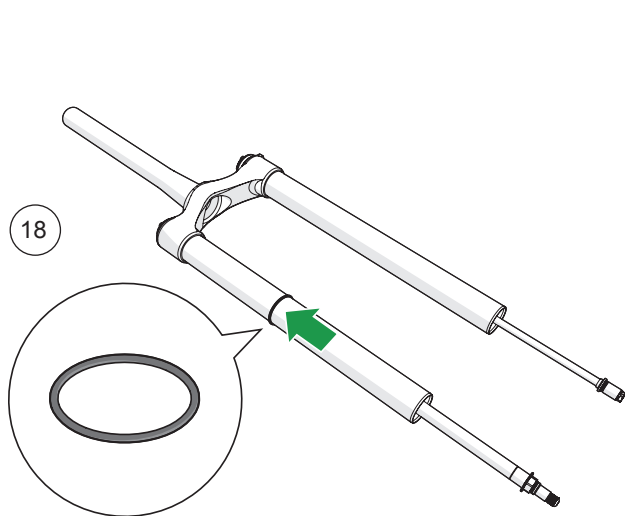
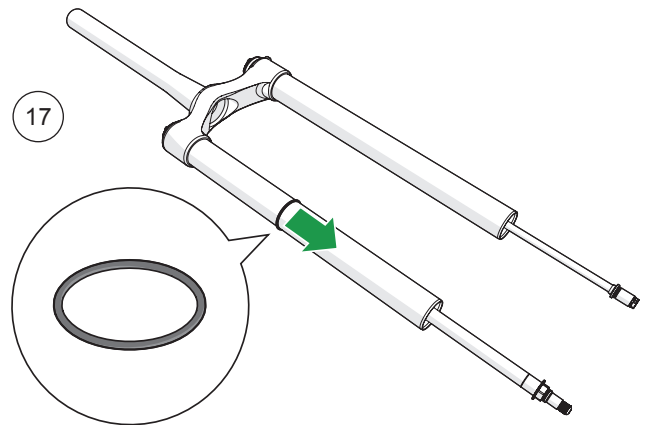
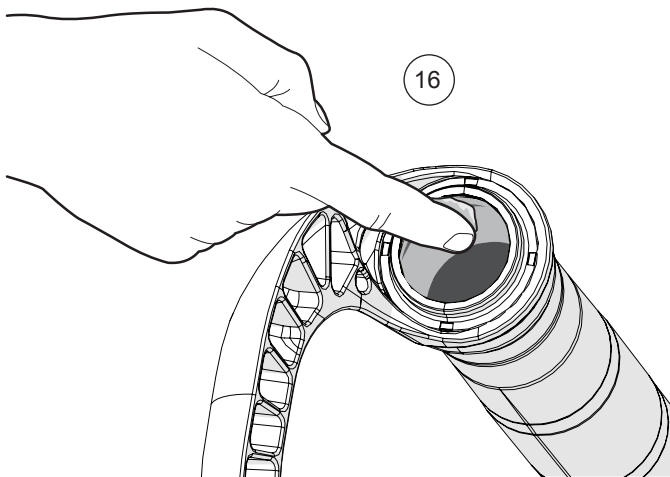
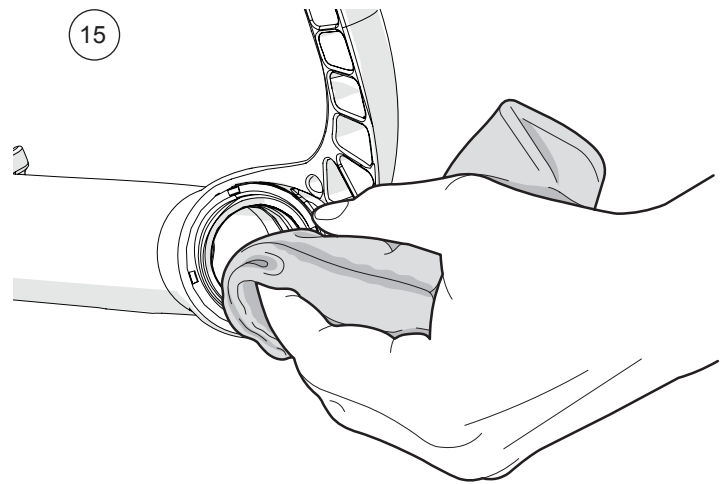

RXF34 M.2/RXC34 M.1 FRONT FORK 100 H SERVICE

Air spring Cartridge 100-hour service

👁 Note!

Clean all parts using disc brake cleaner and a rag to remove dirt, old grease and thread sealant before reassembling. Lubricate new o-rings/x-rings etc. with fresh assembly grease if no other grease is specified.

1. Ensure that there is no pressure left in the air spring by depressing the schrader valve.
2. Place the fork in a vice.
3. Use a socket wrench with a cassette locking socket to loosen the air spring top cap.
4. Remove the old o-ring (00638-62) from the top cap.
5. Install the new o-ring (00638-62) on the top cap.

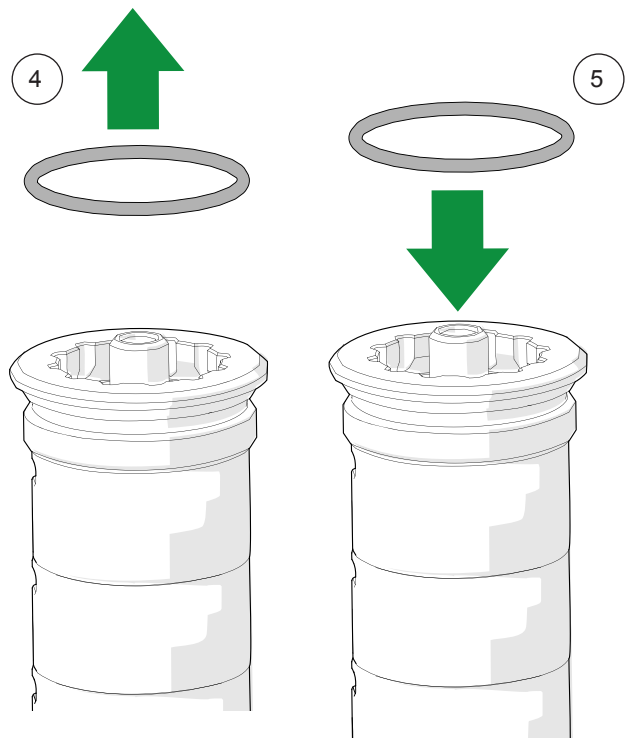
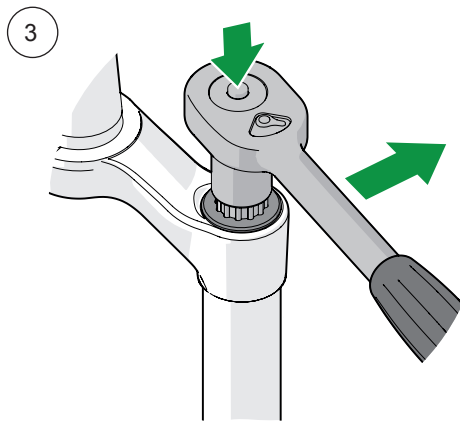
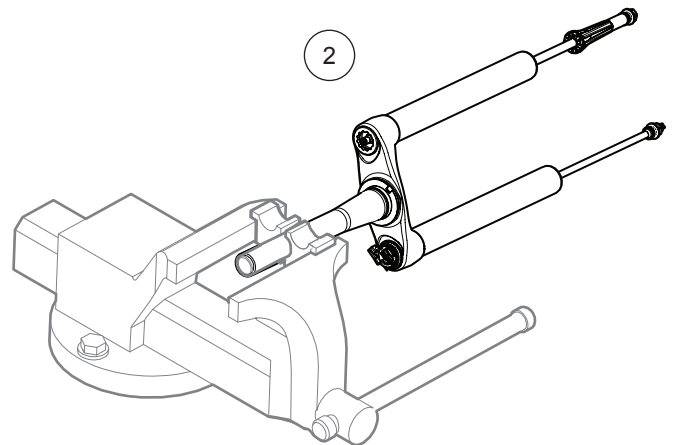

RXF34 M.2/RXC34 M.1 FRONT FORK 100 H SERVICE

6. Remove the screws with a 2 mm hex key.
7. Slide the seal head cap out of the tube. Remove the circlip (19528-01) and discard it. Be careful not to scratch the piston rod.
8. Pull on the piston rod gently until the seal head comes out.

Note!

Clean all parts using disc brake cleaner and a rag to remove dirt, old grease and thread sealant before reassembling. Lubricate new o-rings/x-rings etc. with fresh assembly grease if no other grease is specified.

9. Remove the inner circlip (00329-21) and discard it.

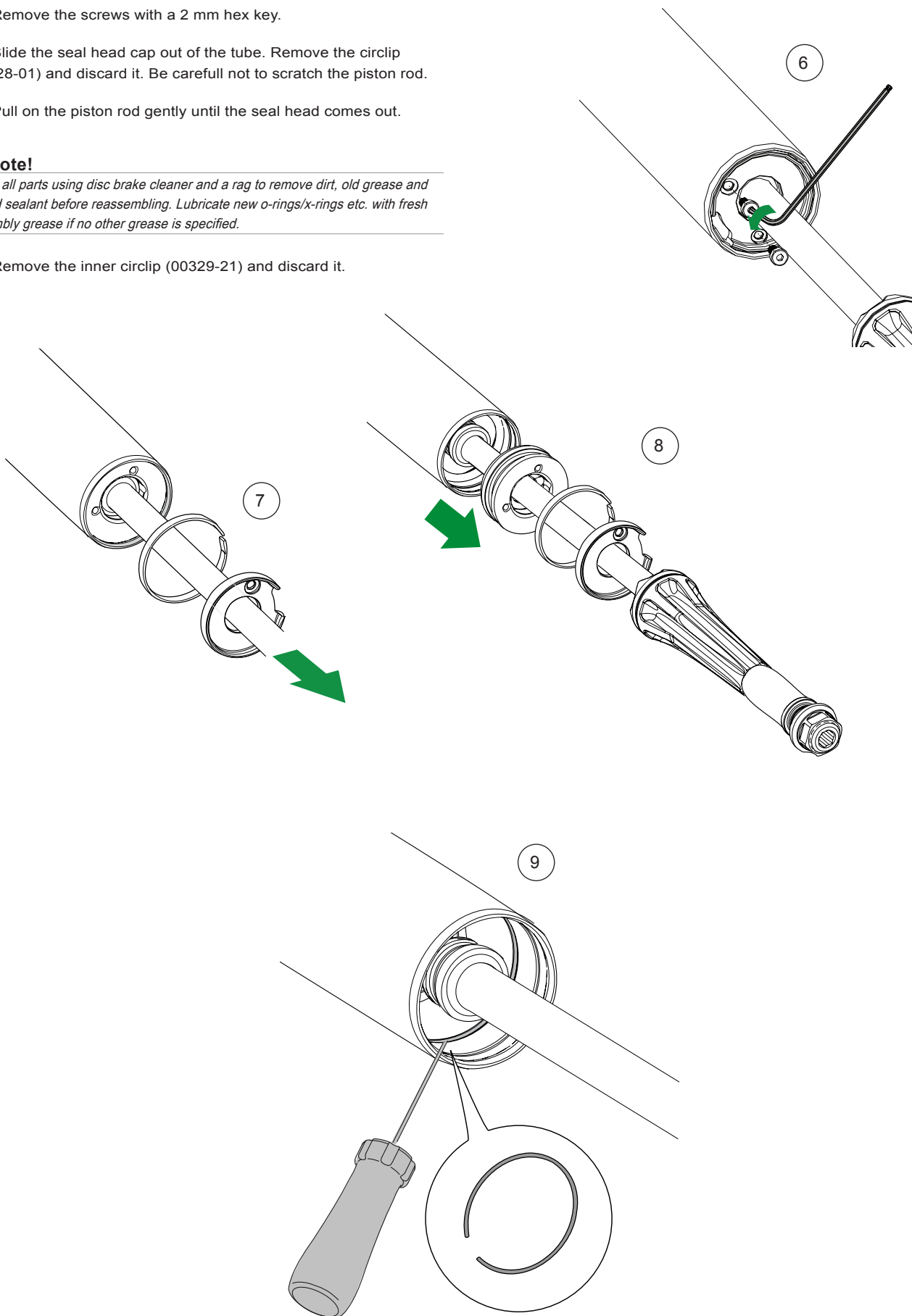

RXF34 M.2/RXC34 M.1 FRONT FORK 100 H SERVICE

10. Remove the air spring from the stanchion.

11. Remove the o-ring (00638-85) from the seal head (Only RXF34 m.2 Air spring shown in picture.).

12. Remove the back-up rings (19525-01) and the X-ring (01027-25) from the piston.

13. Carefully clean the piston using disc brake cleaner and a paper cloth or rag to remove old grease and dirt.

14. Remove the o-ring (00338-57) from the rod end.

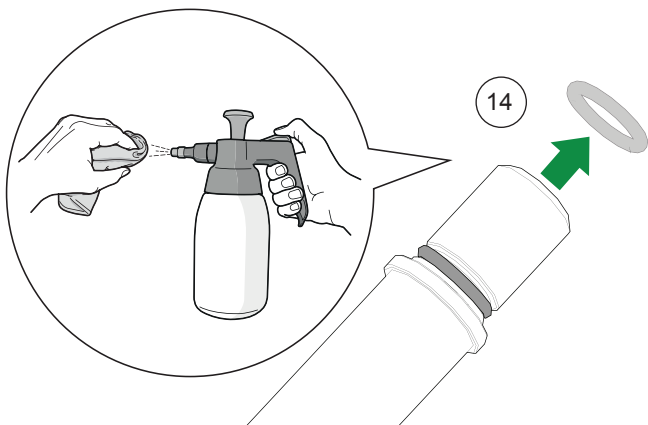
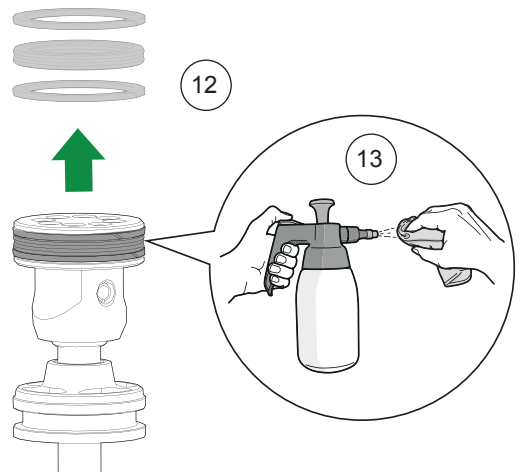
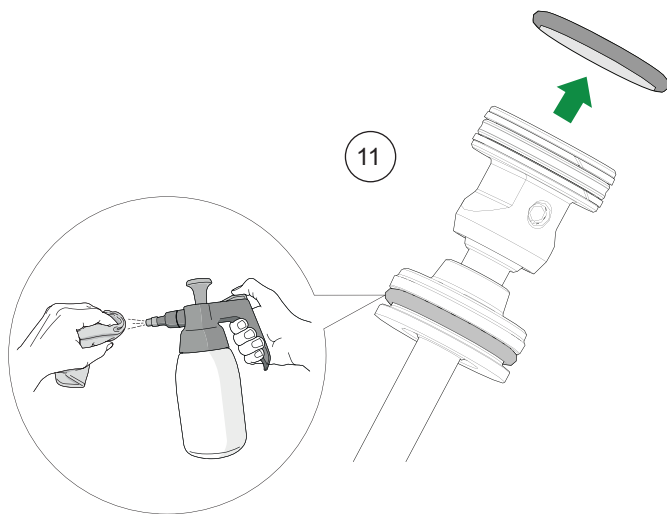
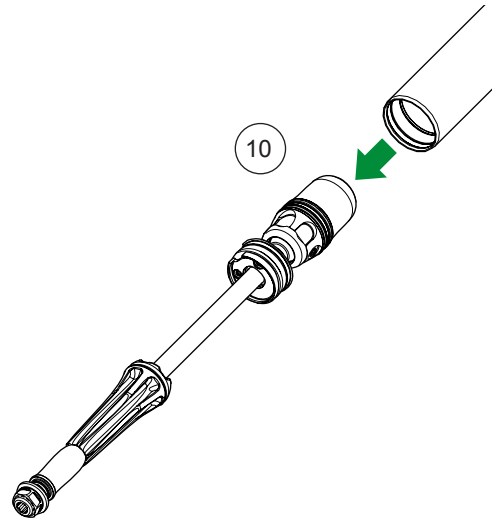

RXF34 M.2/RXC34 M.1 FRONT FORK 100 H SERVICE

Note!

Clean all parts using disc brake cleaner and a rag to remove dirt, old grease and thread sealant before reassembling. Lubricate new o-rings/x-rings etc. with fresh assembly grease if no other grease is specified.

15. Clean the inside of the stanchion tube using disc brake cleaner and a soft rag. Use a rod to push the rag thru the stanchion. Be careful not to scratch the surface of the stanchions.

16. Apply a small amount of function grease all around the new x-ring (01027-25) and the new back-up rings (19525-01).

17. Install the new x-ring (01027-25) on the piston.

18. Install the new back-up rings (19525-01) on the piston.

19. Install the new o-ring (00638-85) on the seal head.

20. Install the new o-ring (00338-57) on the rod end.

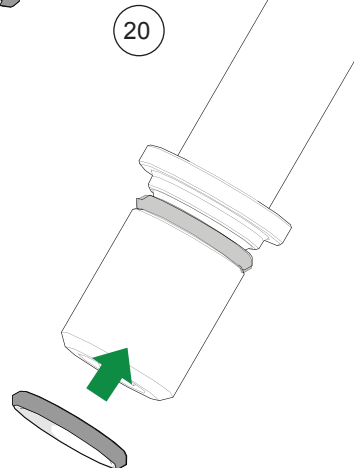
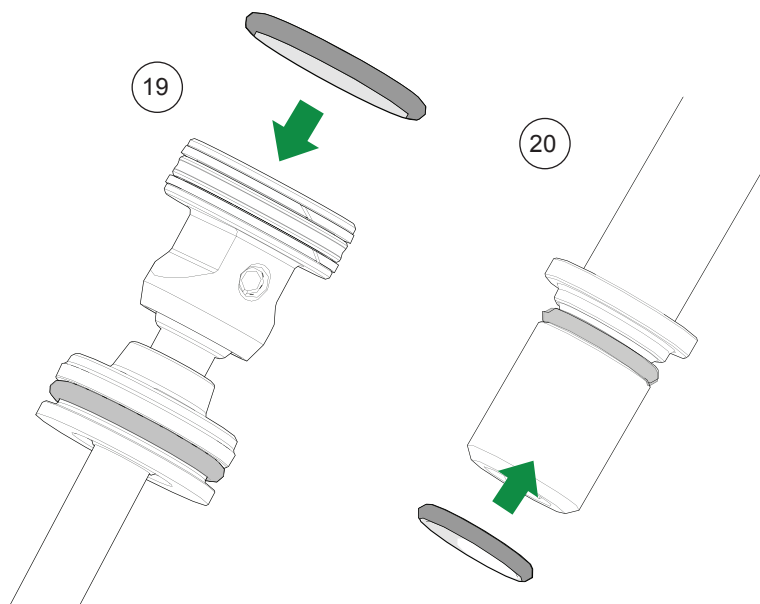
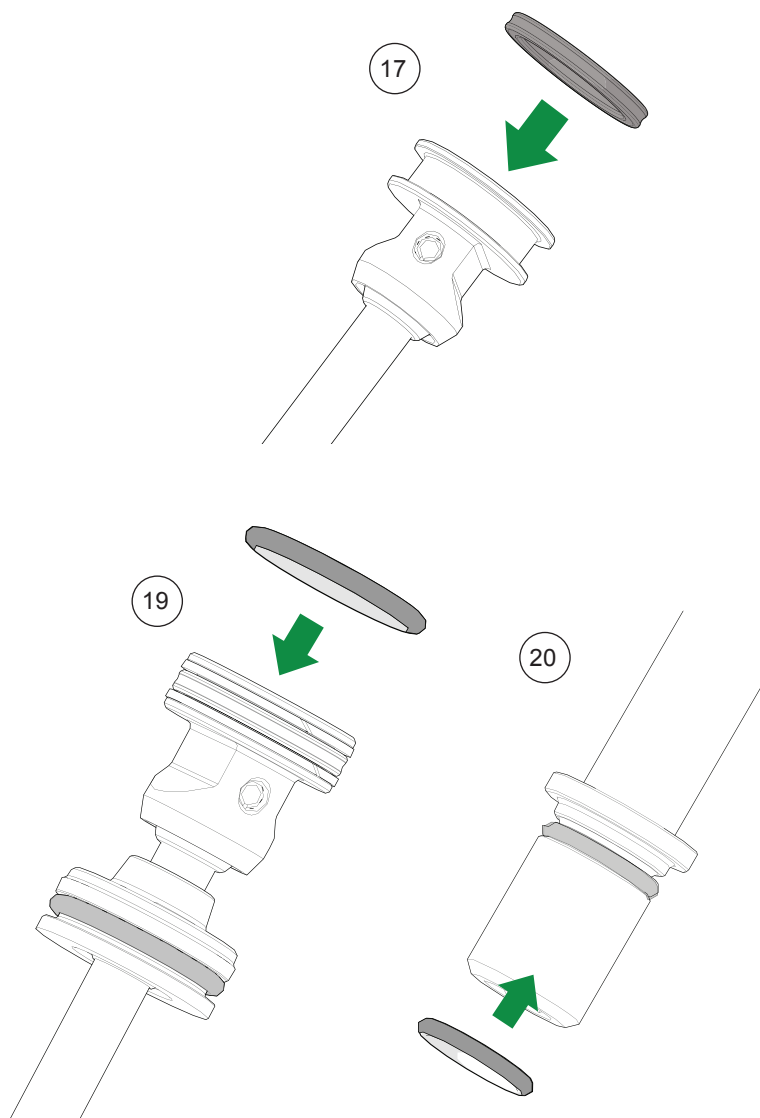
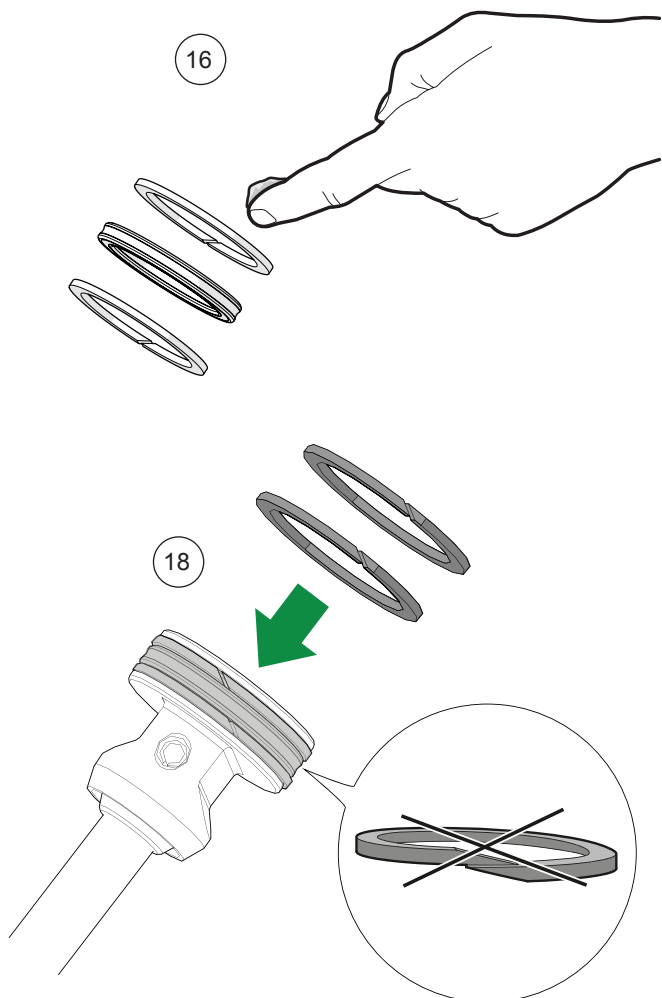
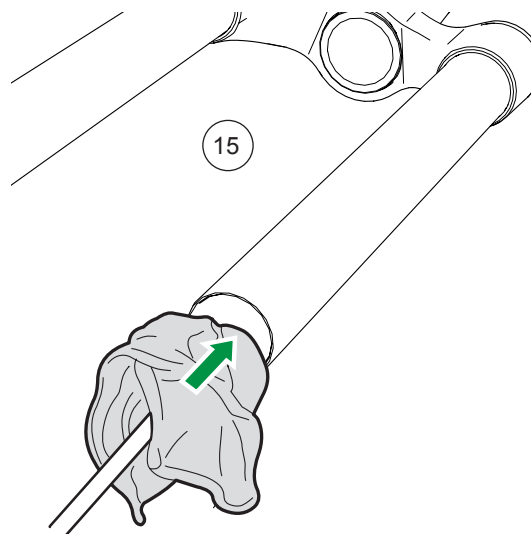

RXF34 M.2/RXC34 M.1 FRONT FORK 100 H SERVICE

👁 Note!

Clean all parts using disc brake cleaner and a rag to remove dirt, old grease and thread sealant before reassembling. Lubricate new o-rings/x-rings etc. with fresh assembly grease if no other grease is specified.

21. Reinstall the top cap and volume spacers. Use a torque wrench with a cassette locking socket to tighten the top cap to 32 Nm.

22. Apply 2 ml of function grease at the inside of the stanchion tube inside the two circlip grooves (air spring side) (smeared around). Add 1 ml of air spring lubrication fluid distributed on top of the grease.

23. Apply a thin layer of function grease on the X-ring and the back-up rings on the piston.

24. Insert the piston into the stanchion tube, depressing the schrader valve to relieve the pressure.

25. Install the new circlip (00329-21) in the inner most circlip groove. Be carefull not to damage the Stanchion tube surface while installing the circlip.

👁 Note!

Clean all parts using disc brake cleaner and a rag to remove dirt, old grease and thread sealant before reassembling. Lubricate new o-rings/x-rings etc. with fresh assembly grease if no other grease is specified.

26. Apply 1 ml of air spring lubrication fluid inside the negative chamber.

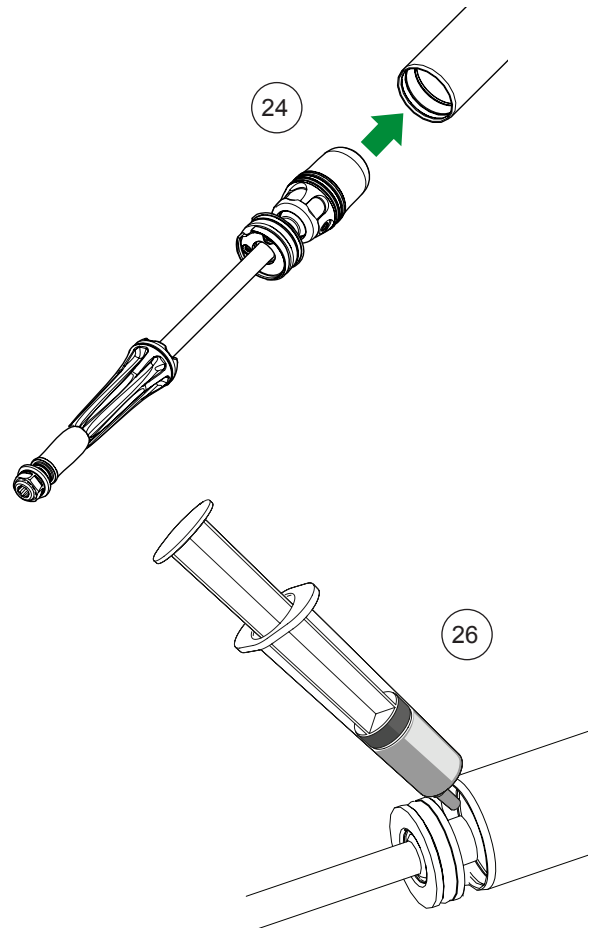
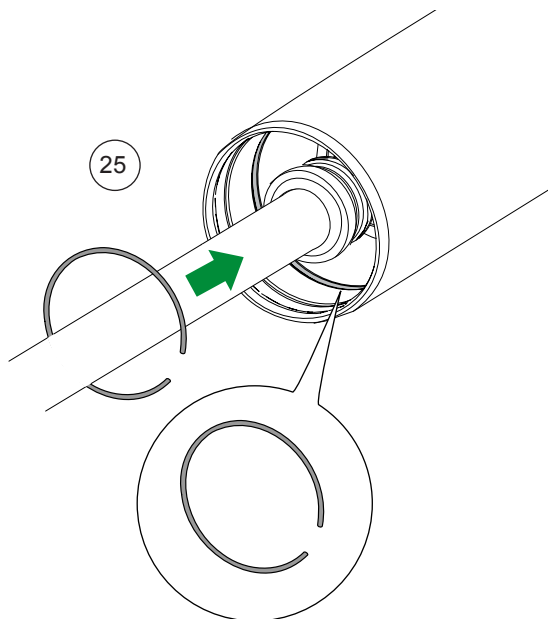
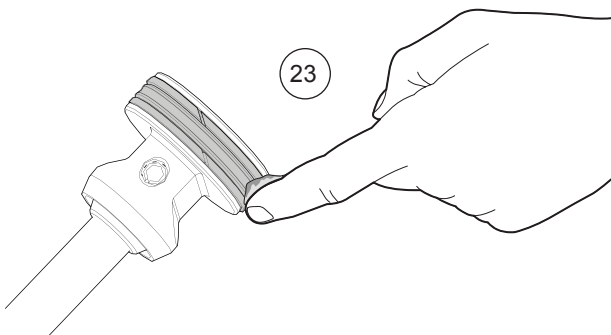
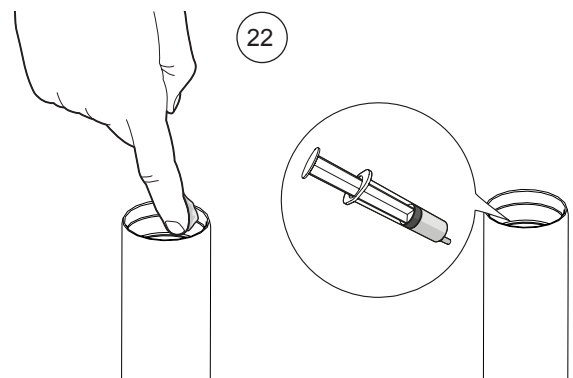
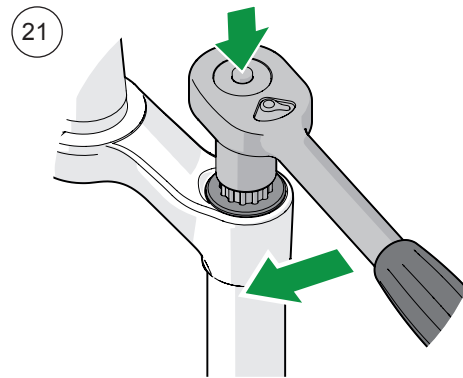

RXF34 M.2/RXC34 M.1 FRONT FORK 100 H SERVICE

27. Gently push the seal head into the stanchion tube. It should come to a firm stop about 6 mm from the edge of the stanchion tube if the inner circlip (00329-21) is properly seated.

Important! Clean the outer most circlip groove from any remaining grease using a rag and disc brake cleaner. Failing to do so might cause the circlip not to seat itself properly in the groove.

28. Install the new circlip (19528-01). Be careful not to damage the piston rod surface while installing the circlip.

Important! Make sure the circlip is properly seated in the groove before continuing.

29. Reinstall the seal head cap with a 2 mm hex key. Tighten to 1.3 Nm.

30. Clean the stanchion tubes with a paper cloth or soft rag.

31. Inflate the main chamber to the desired air pressure and cycle the spring until the main and negative chamber pressures are equalized.

32. Reinstall the lower legs on to the stanchions.

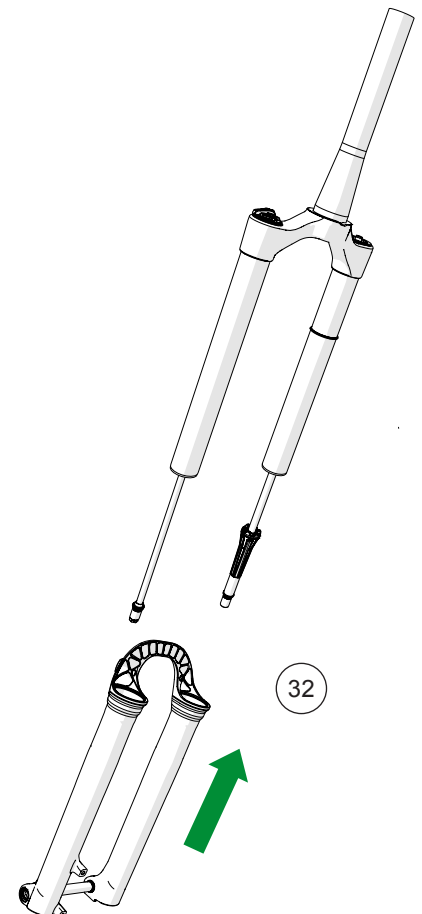
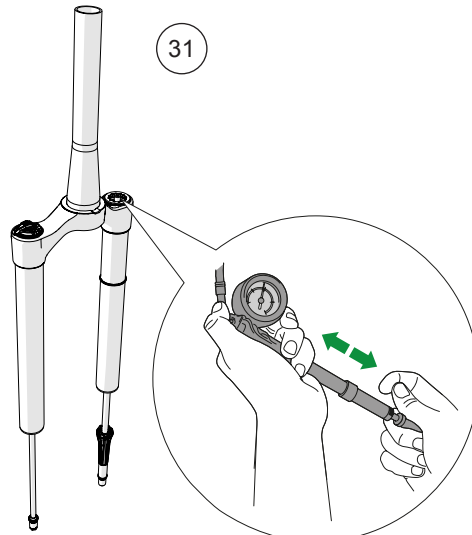
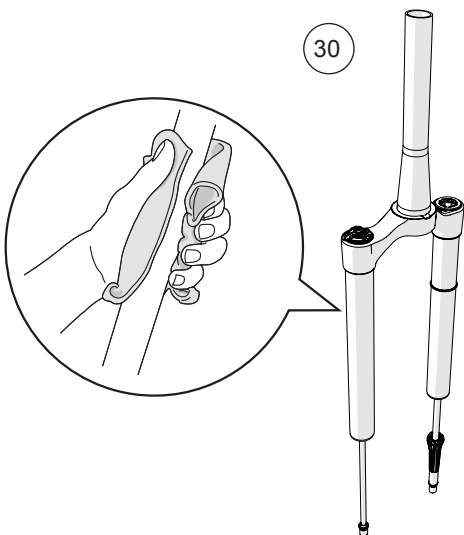
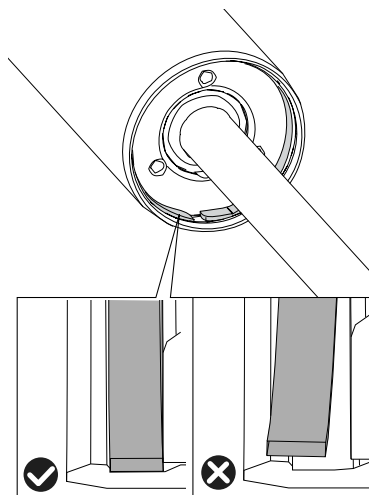
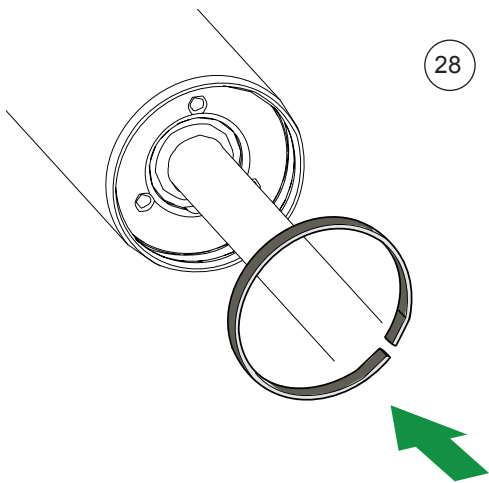
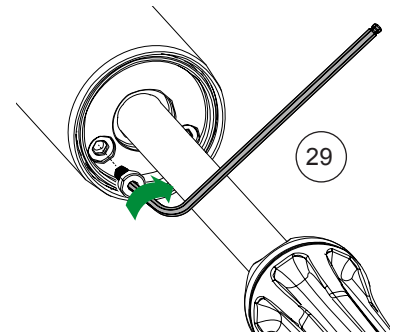
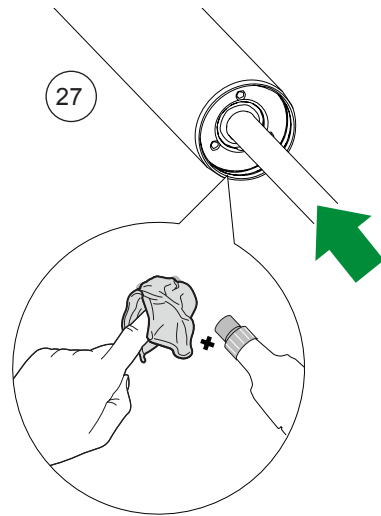

RXF34 M.2/RXC34 M.1 FRONT FORK 100 H SERVICE

33. Inject fluids in spring and damper fork leg according to table below. The volumes are critical as they will affect fork performance.

Model	Fork part no.	Damper fork leg		Spring fork leg	
		Oil	Volume	Oil	Volume
RXF34 m.2	FGxxx 34xx 22xx	Damper fluid	10 ml	Fork lubrication fluid	10 ml
RXC34 m.1	FGxxx 34xx 23xx				

See appendix A and B to determine the part no. of the fork.

34. Reinstall the nuts. Use a torque wrench with a 14 mm hex socket and tighten to 10 Nm.

35. **Only RXF34:** Reinstall the rebound adjuster knob and screw. Use a 14 mm wrench to hold the knob steady. With a 2 mm hex wrench tighten the screw and knob.

36. Adjust the rebound setting according to the value recorded.

37. Adjust the LSC and HSC setting according to the values recorded.

38. Replace the air valve lid.

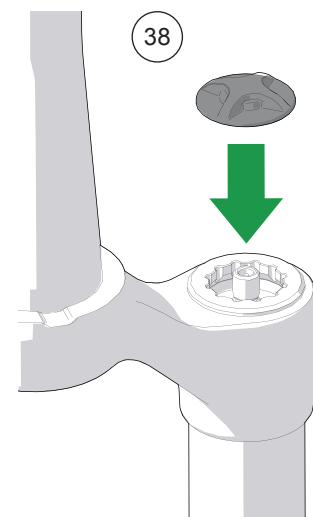
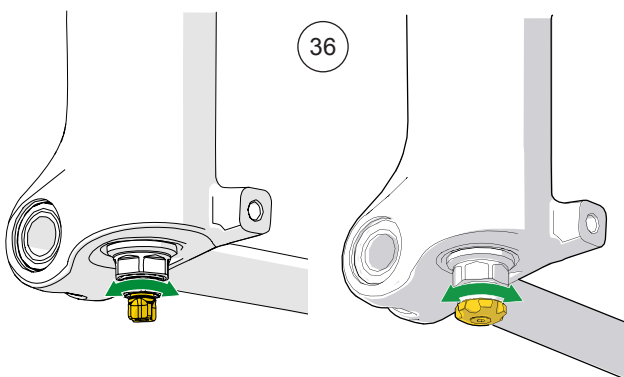
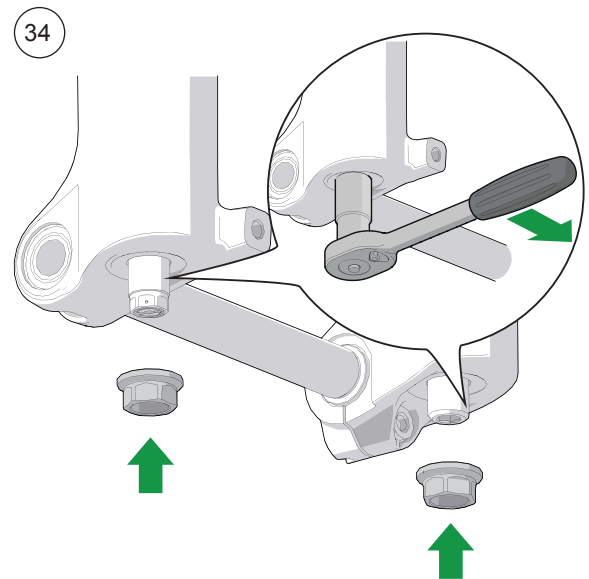
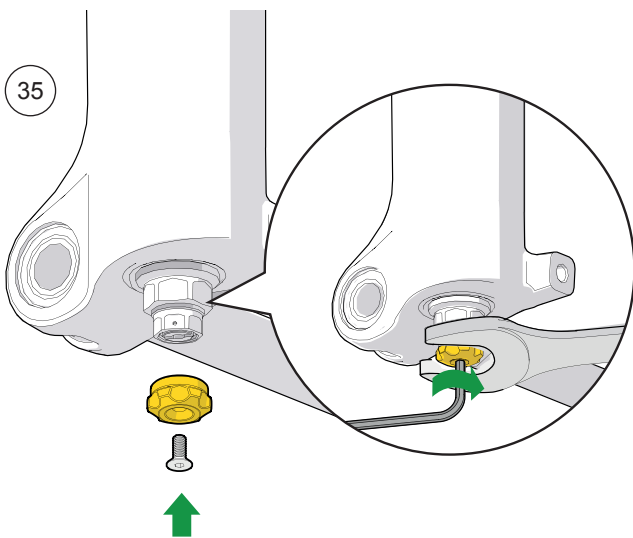
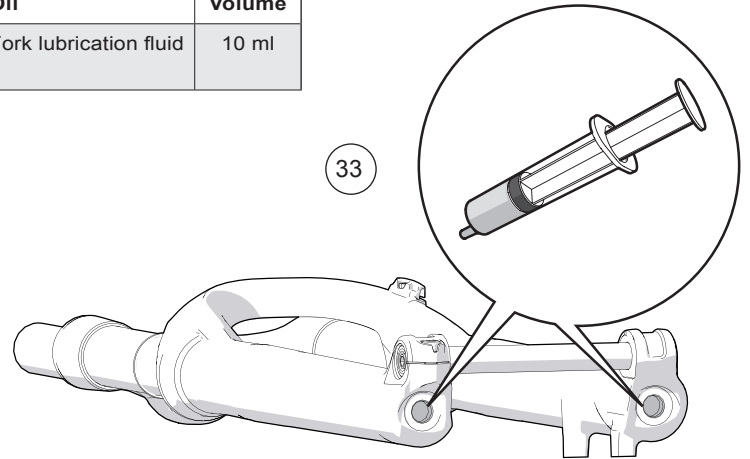

RXF34 M.2/RXC34 M.1 FRONT FORK 100 H SERVICE

Appendix A. RXF34 m.2/ RXC34 m.1

Part no of the fork can be found at the bottom of the steerer tube.

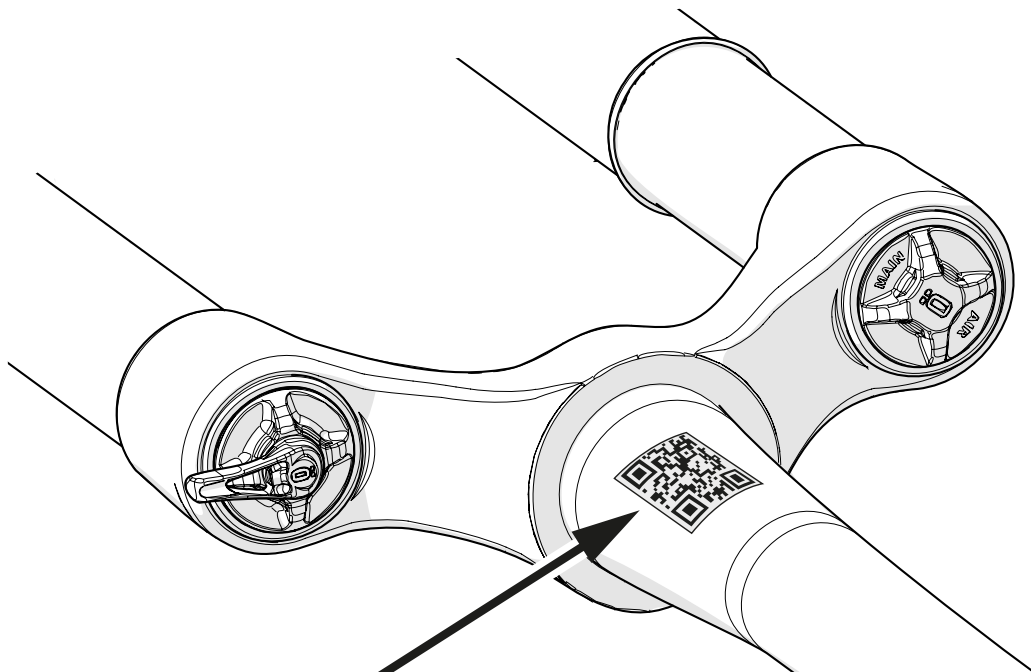
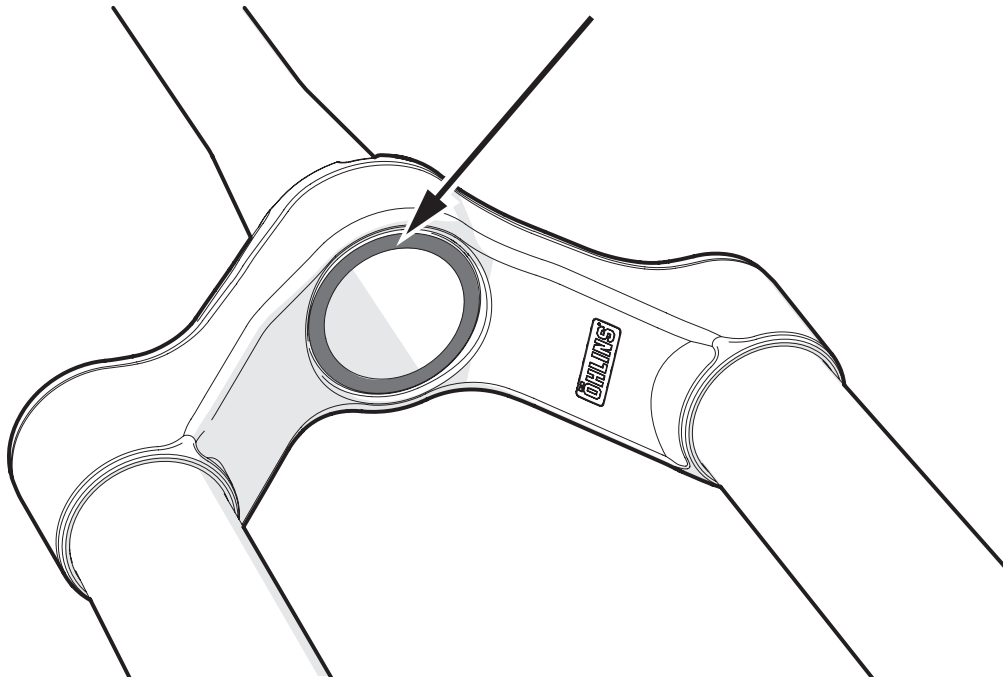

The part no of the fork can also be found on the steerer tube as a QR-code. Use a QR-code reader in a smartphone to receive the part no.

RXF34 M.2/RXC34 M.1 FRONT FORK 100 H SERVICE

Appendix B. RXC34 m.1 Carbon

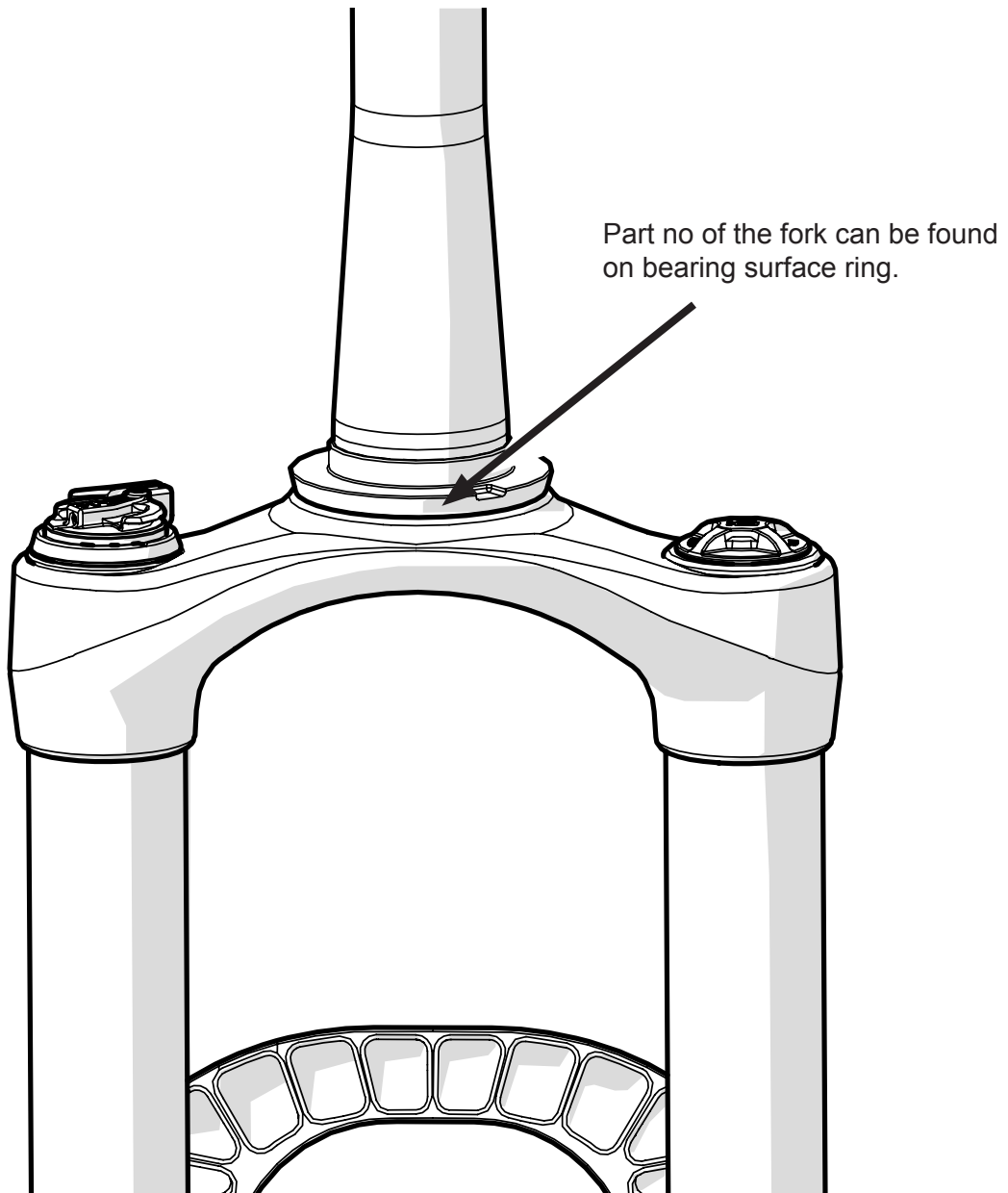

Your Öhlins retailer:

Öhlins Racing AB
Box 722
SE-194 27, Upplands Väsby
Sweden

Phone: +46 (0)8 590 025 00
Fax: +46 (0)8 590 025 80
www.ohlins.com



www.ohlins.com